

HYBRID-SCHLEIFRINGE PNEUMATIK + ELEKTRIK

RX-PNxx01 Serie	p.1	RX-PNxx04 Serie	p.14	RX-PNxx10 Serie	p.24
RX-PNxx02 Serie	p.3	RX-PNxx06 Serie	p.20	RX-PNxx12 Serie	p.24
RX-PNxx03 Serie	p.9	RX-PNxx08 Serie	p.23	RX-PNxx16 Serie	p.24

ABMESSUNGEN (in mm)

RX-PNM501-QS2-A - M5 Anschluss

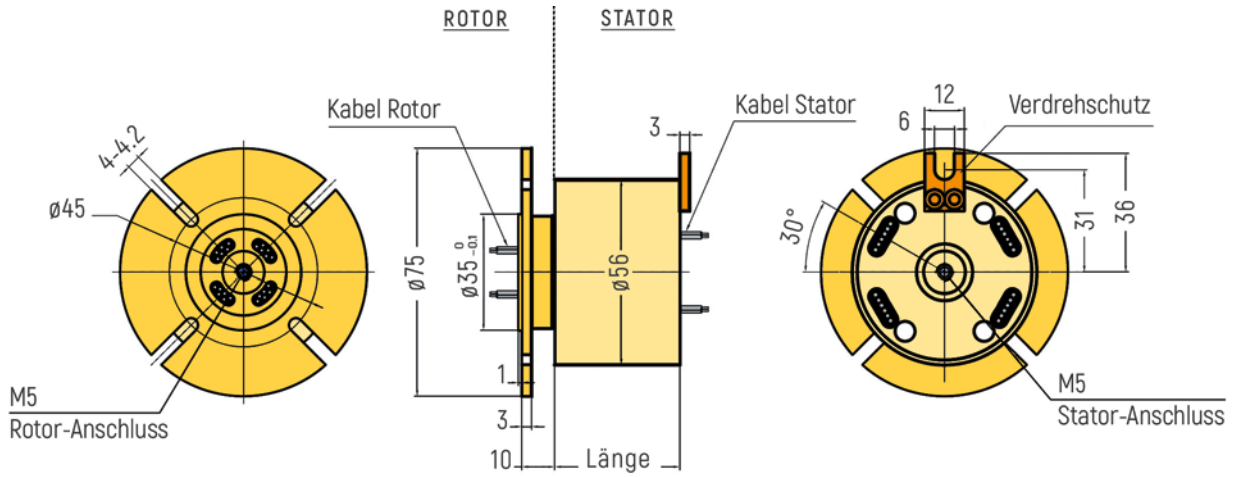

RX-PN1801-QS2-A - G1/8" Anschluss

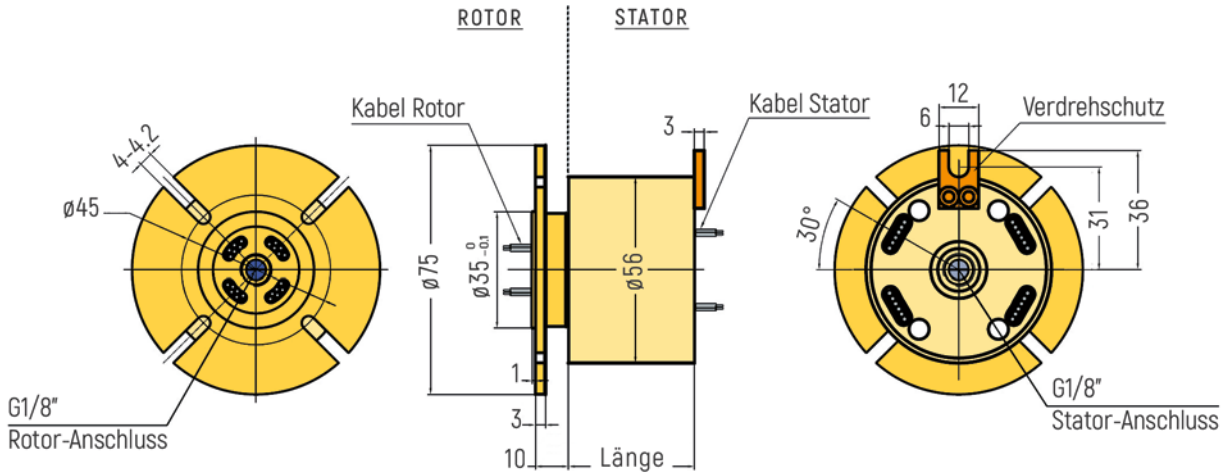

HYBRID-SCHLEIFRINGE PNEUMATIK + ELEKTRIK

ABMESSUNGEN (in mm)

RX-PN1401-QS2-A - G1/4" Anschluss

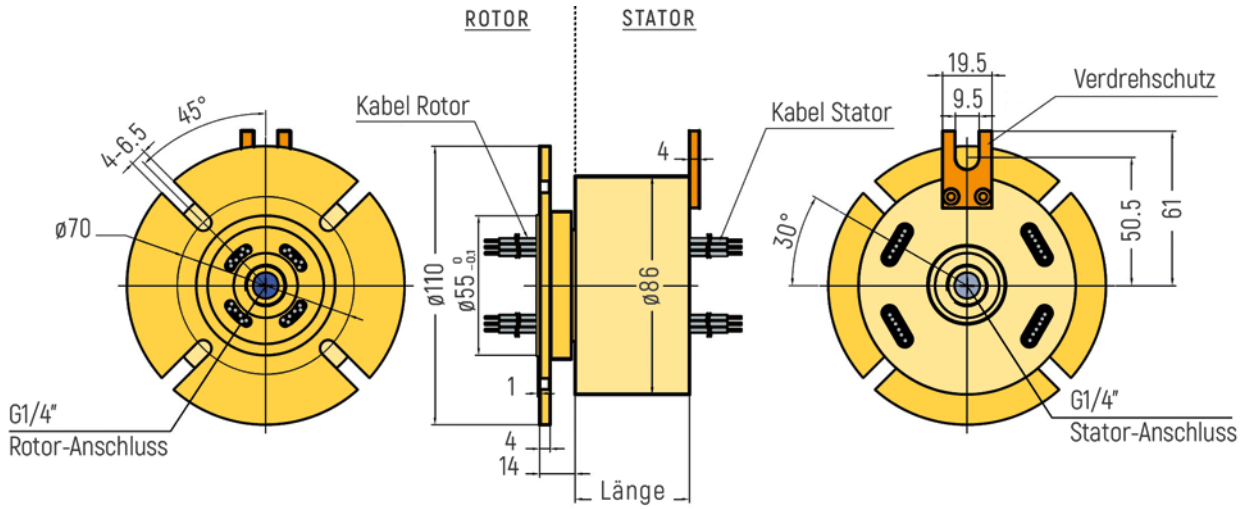

RX-PN3801-QS2-A - G3/8" Anschluss

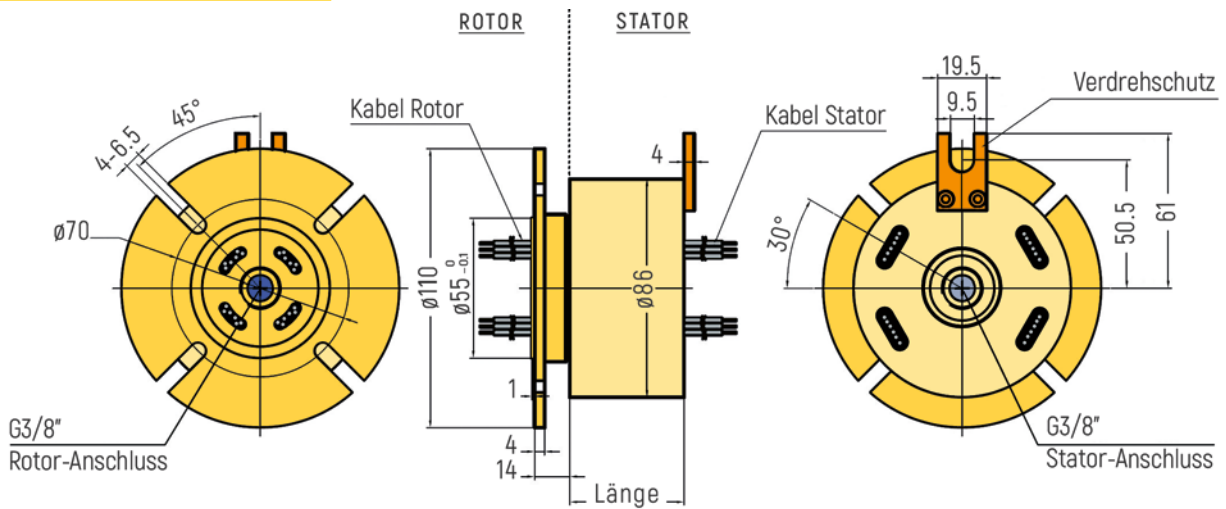

RX-PN1201-QS2-A - G1/2" Anschluss

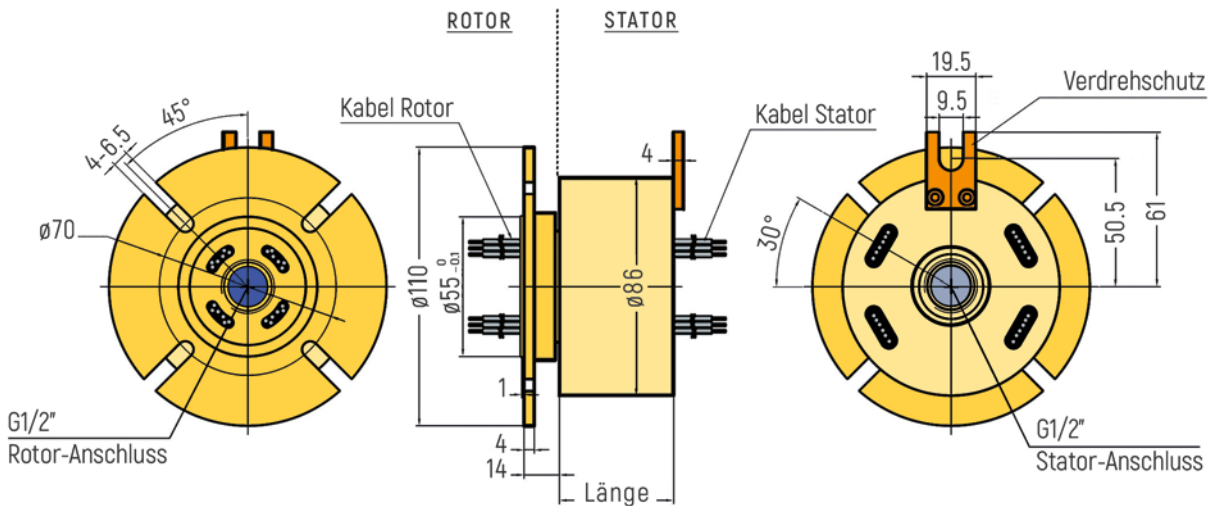

HYBRID-SCHLEIFRINGE PNEUMATIK + ELEKTRIK

ABMESSUNGEN (in mm)

RX-PNM502-QS2-B - M5 Anschluss

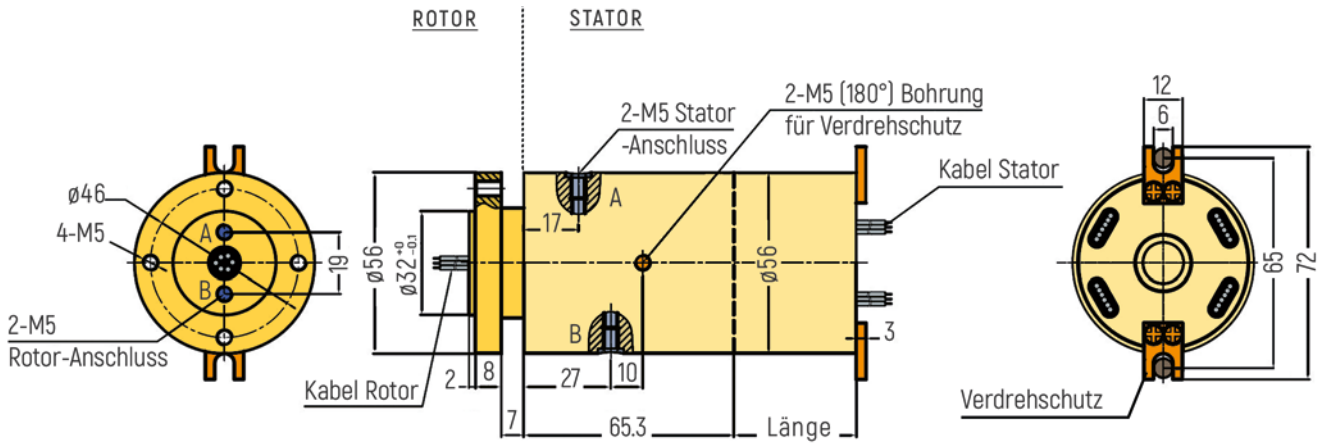

RX-PN1802-QS2-B - G1/8" Anschluss

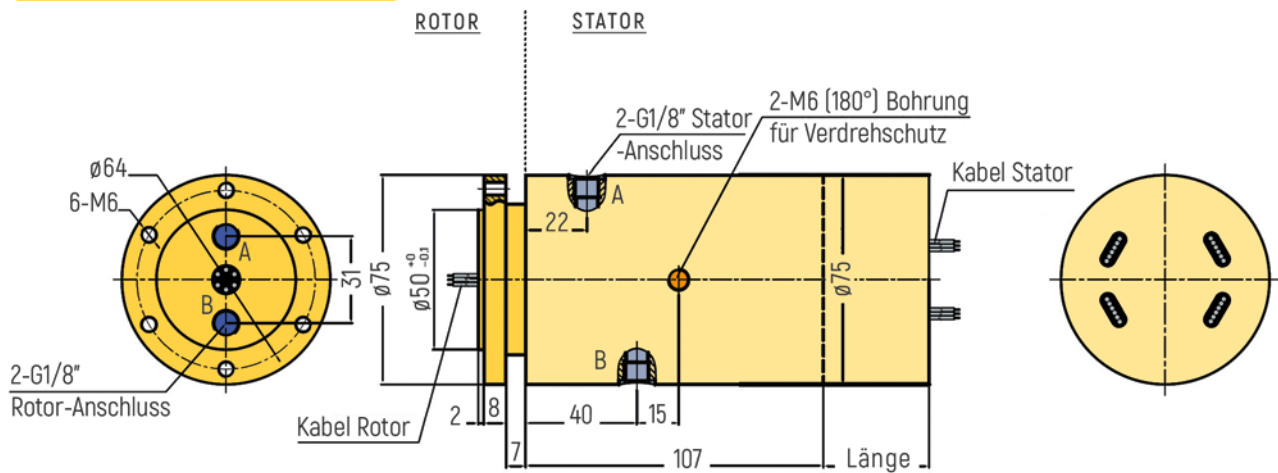

RX-PN1402-QS2-B - G1/4" Anschluss

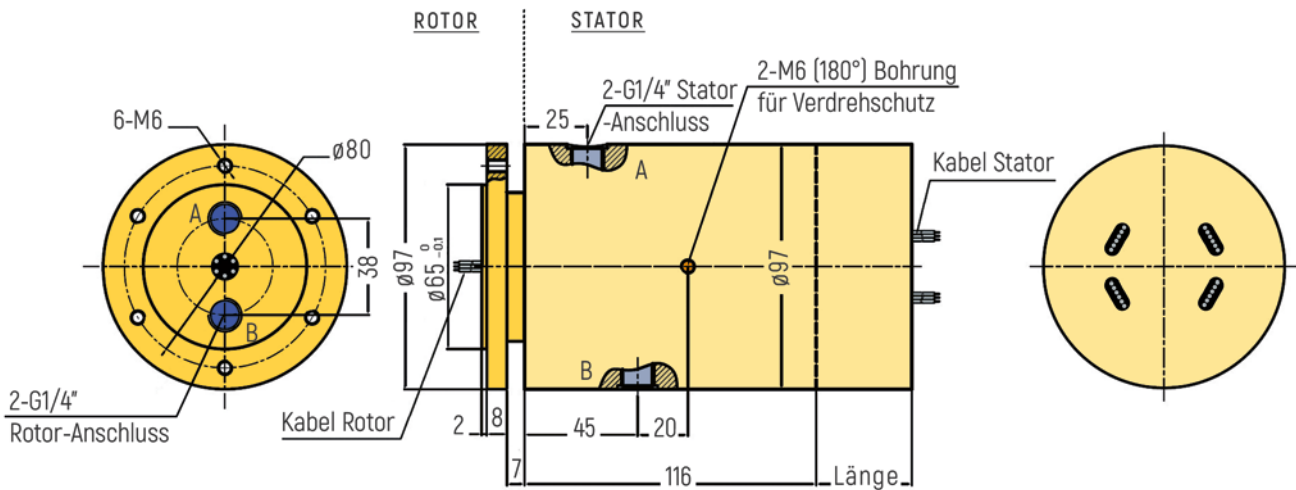

HYBRID-SCHLEIFRINGE PNEUMATIK + ELEKTRIK

ABMESSUNGEN (in mm)

RX-PN3802-QS2-B - G3/8" Anschluss

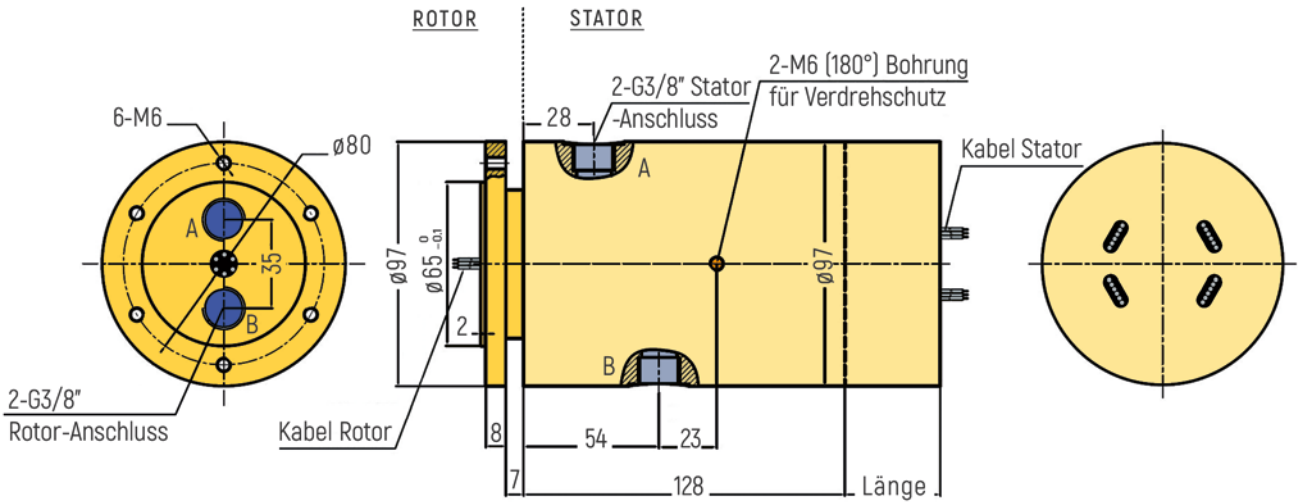

RX-PN1202-QS2-B - G1/2" Anschluss

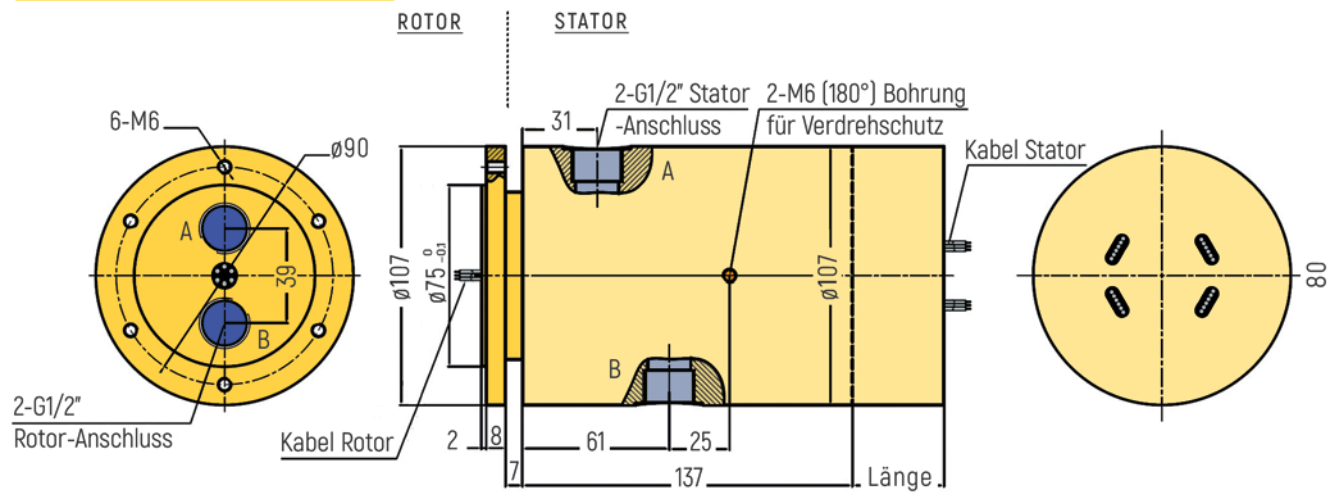

RX-PNM502-QS2-C - M5 Anschluss

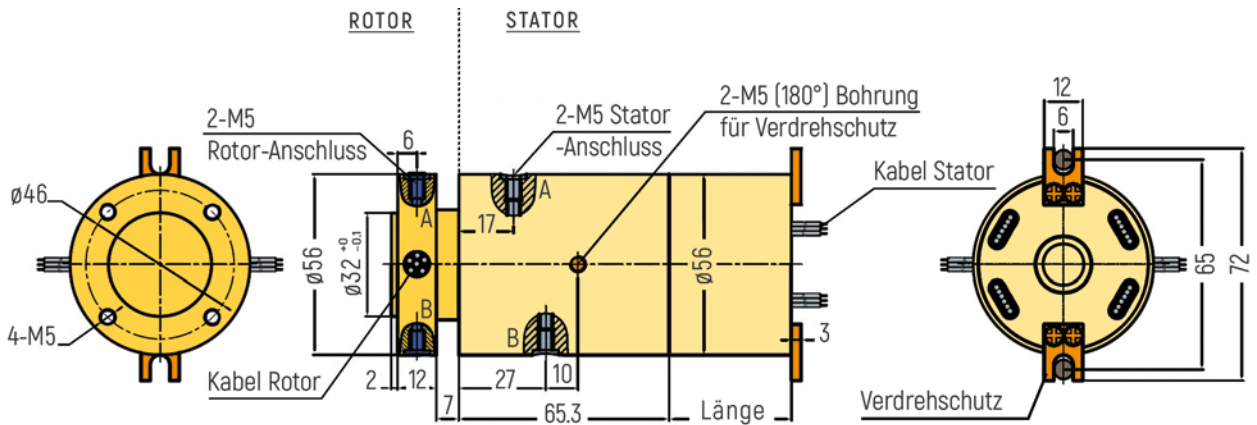

HYBRID-SCHLEIFRINGE PNEUMATIK + ELEKTRIK



ABMESSUNGEN (in mm)

RX-PN1802-QS2-C - G1/8" Anschluss

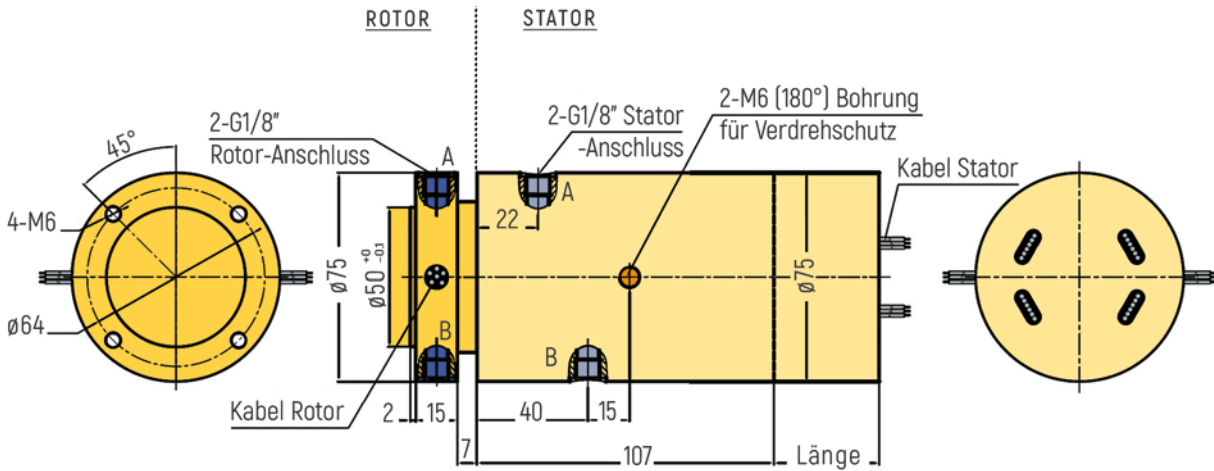

RX-PN1402-QS2-C - G1/4" Anschluss

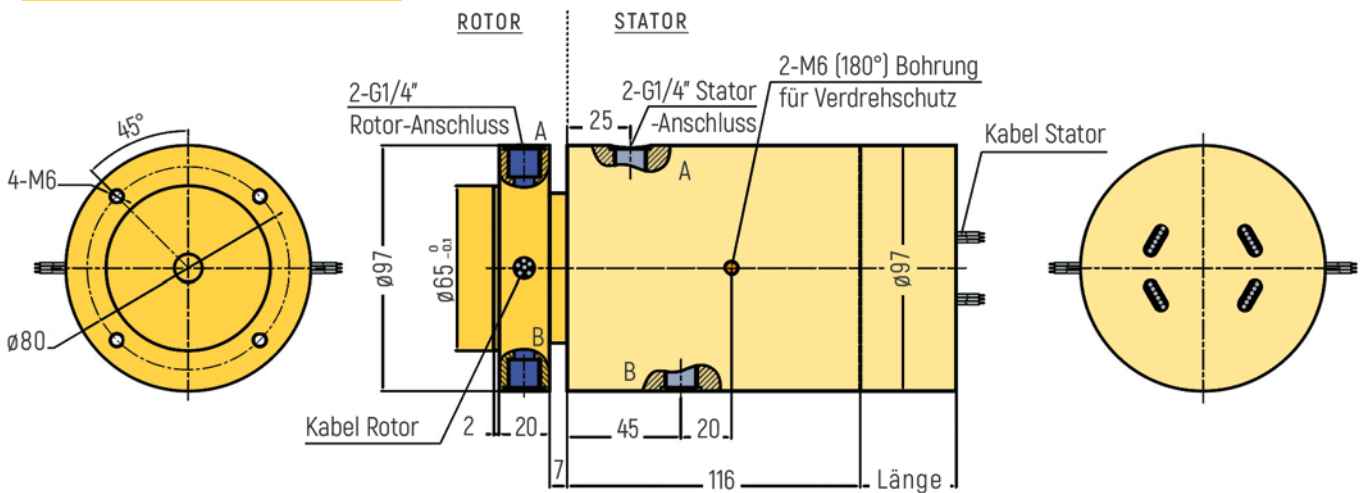

RX-PN3802-QS2-C - G3/8" Anschluss

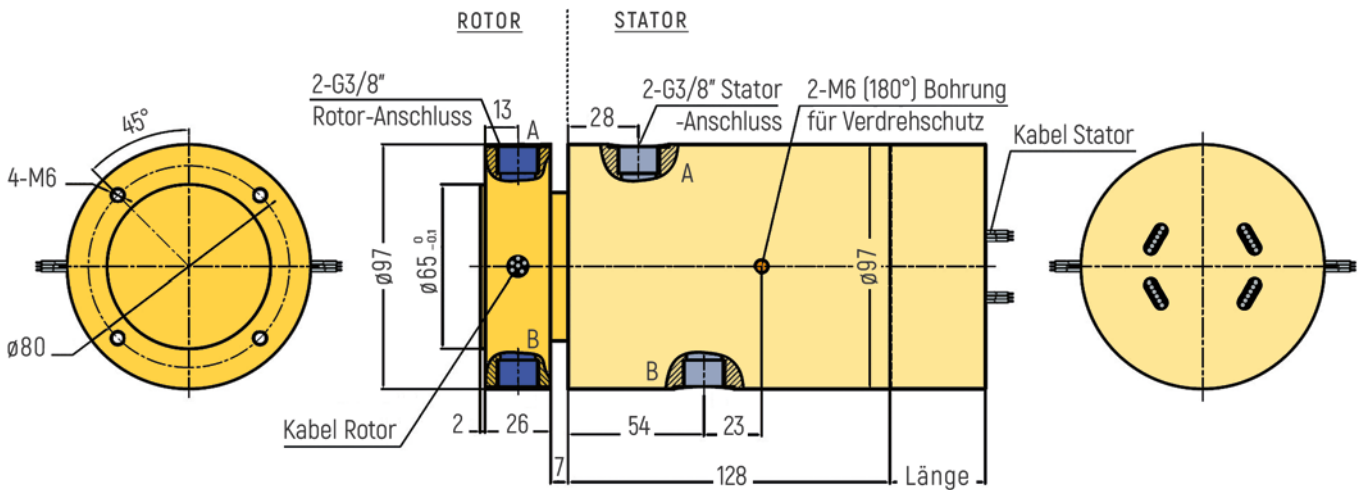

HYBRID-SCHLEIFRINGE PNEUMATIK + ELEKTRIK

ABMESSUNGEN (in mm)

RX-PN1202-QS2-C - G1/2" Anschluss

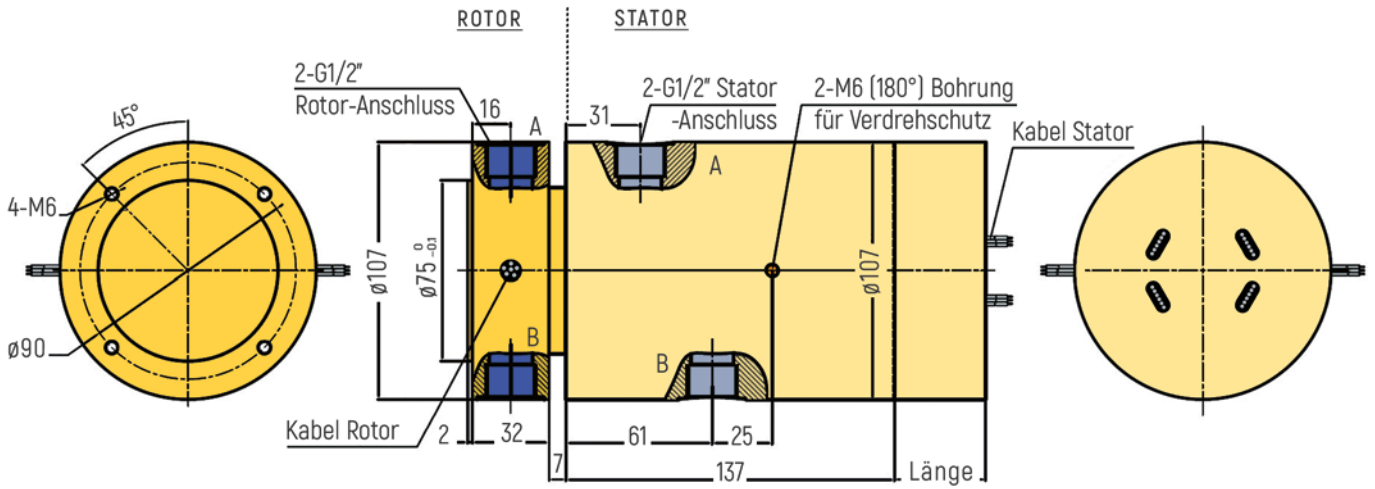

RX-PNM502-QS1-B - M5 Anschluss

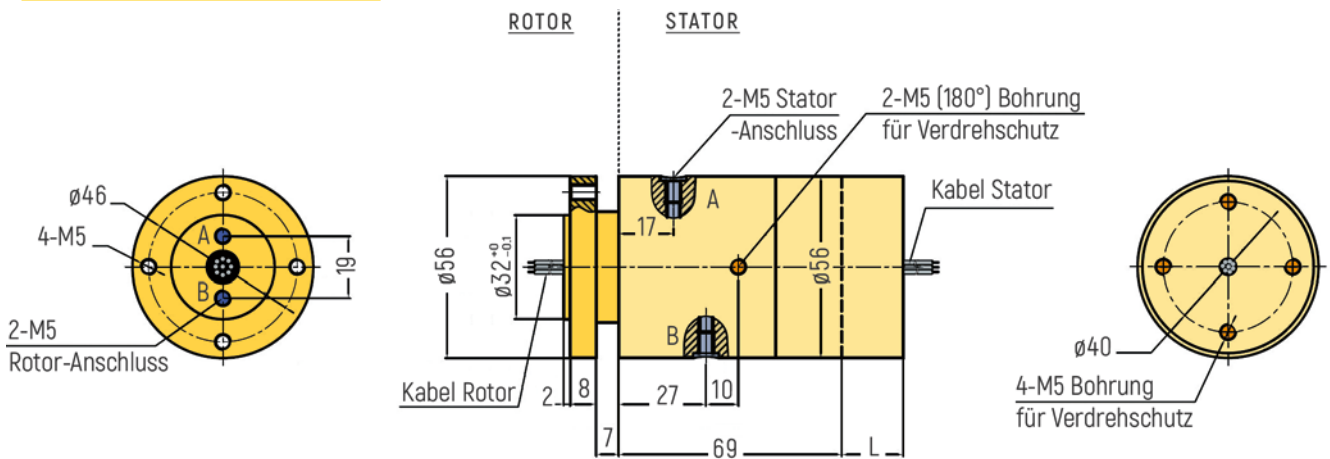

RX-PN1802-QS1-B - G1/8" Anschluss

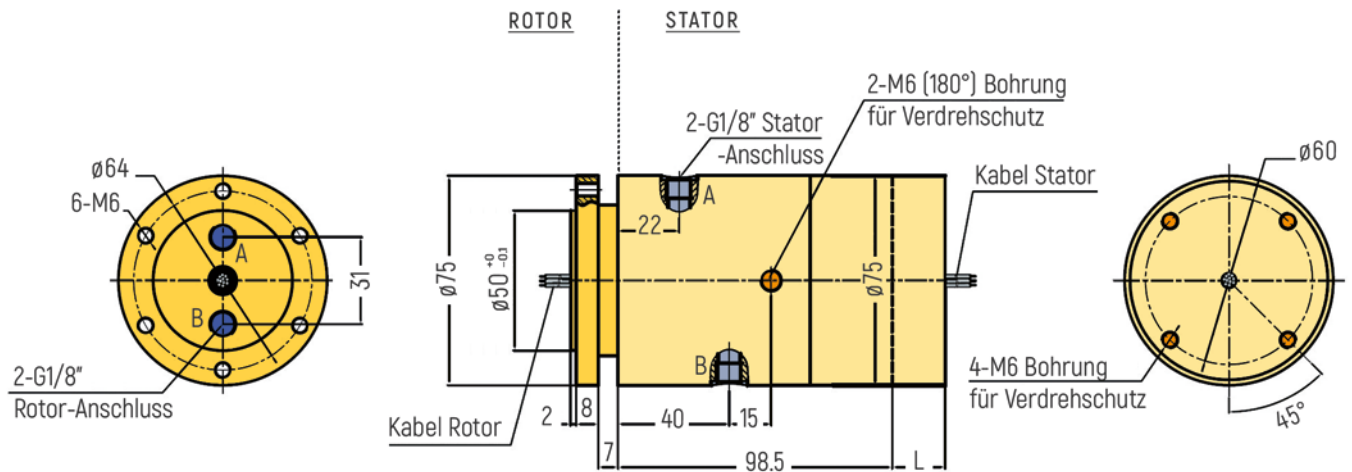

HYBRID-SCHLEIFRINGE PNEUMATIK + ELEKTRIK

ABMESSUNGEN (in mm)

RX-PN1402-QS1-B - G1/4" Anschluss

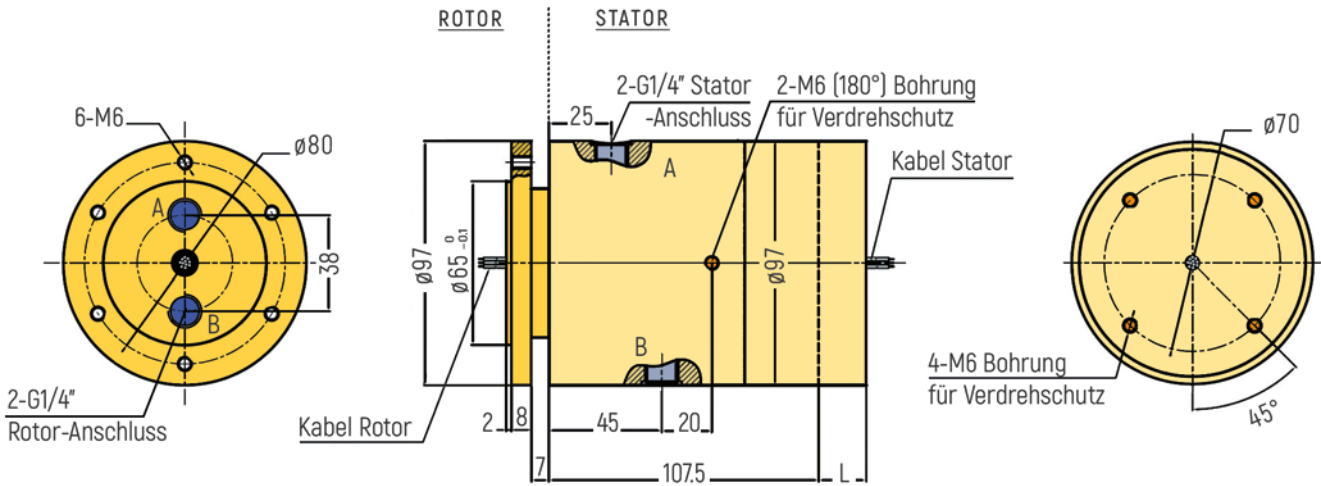

RX-PN3802-QS1-B - G3/8" Anschluss

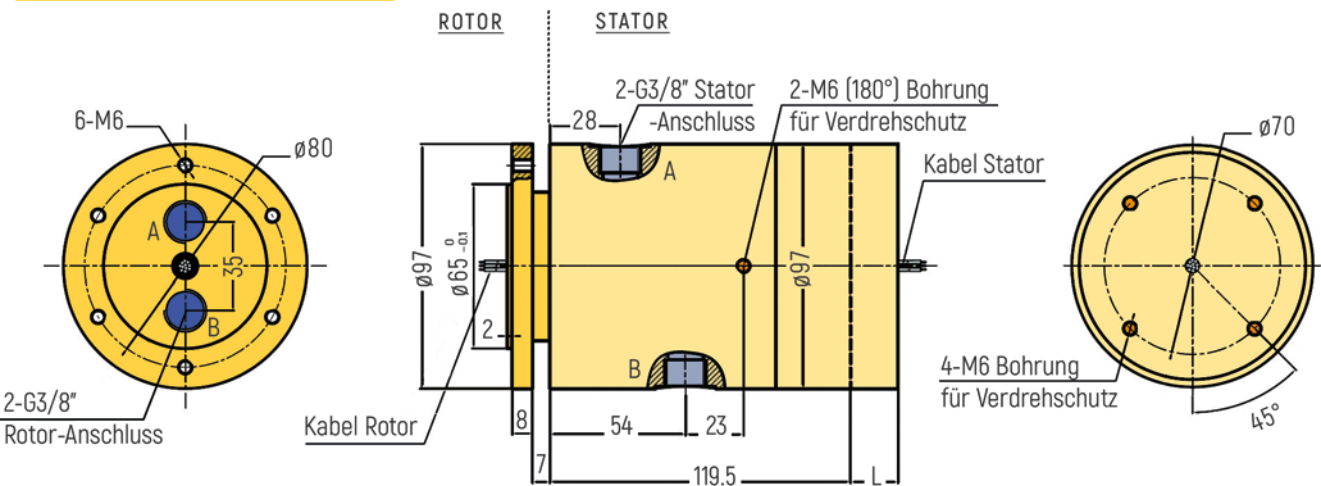

RX-PN1202-QS1-B - G1/2" Anschluss

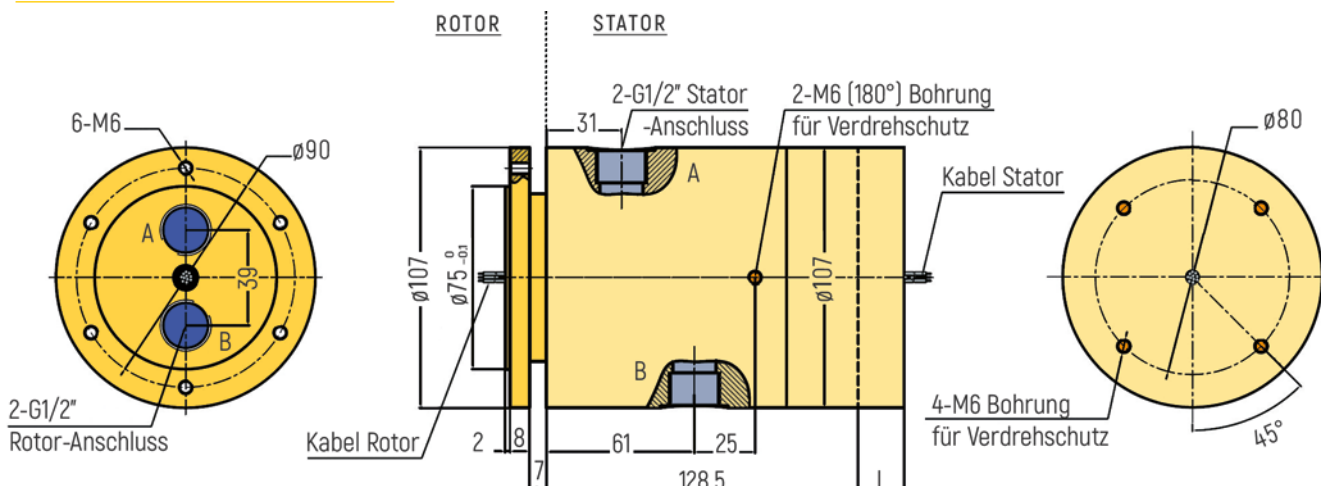

HYBRID-SCHLEIFRINGE PNEUMATIK + ELEKTRIK



ABMESSUNGEN (in mm)

RX-PN1802-QS2-D - G1/8" Anschluss

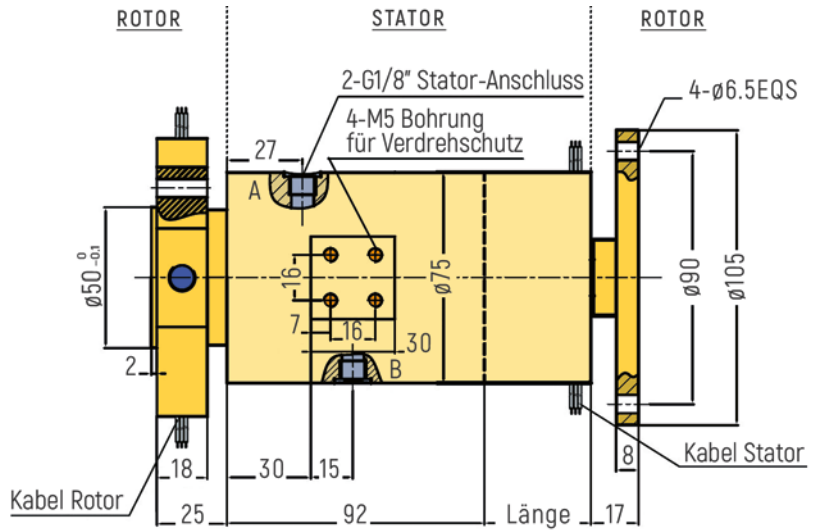
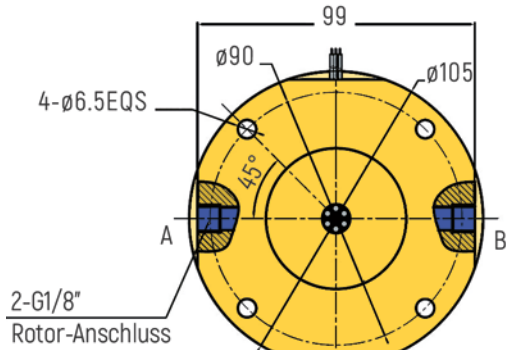

RX-PN1402-QS2-D - G1/4" Anschluss

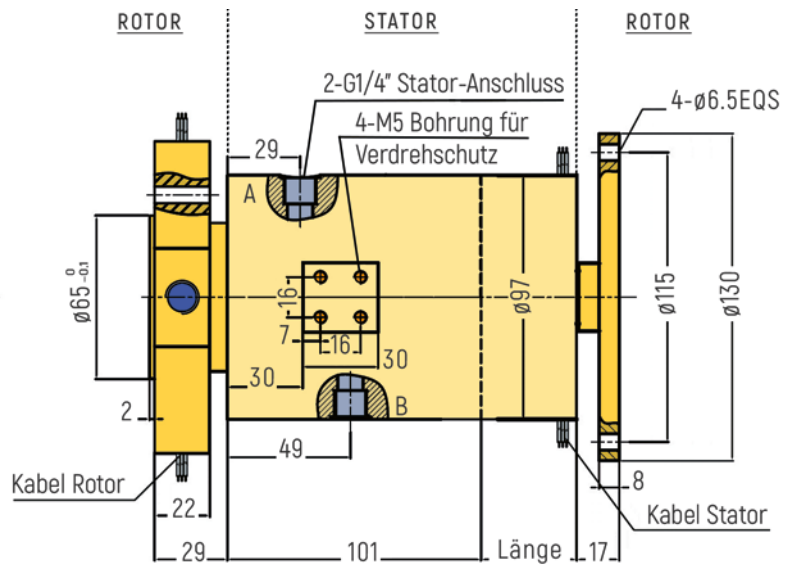
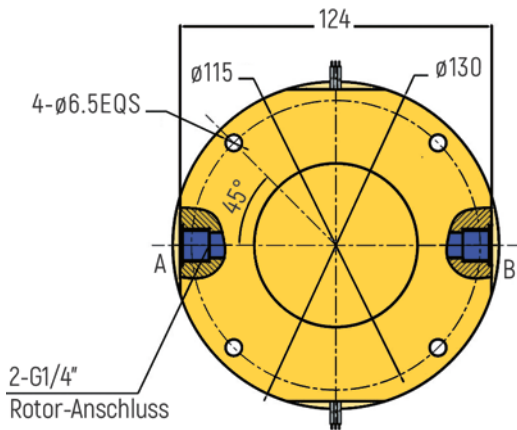

HYBRID-SCHLEIFRINGE PNEUMATIK + ELEKTRIK

ABMESSUNGEN (in mm)

RX-PNM503-QS2-B - M5 Anschluss

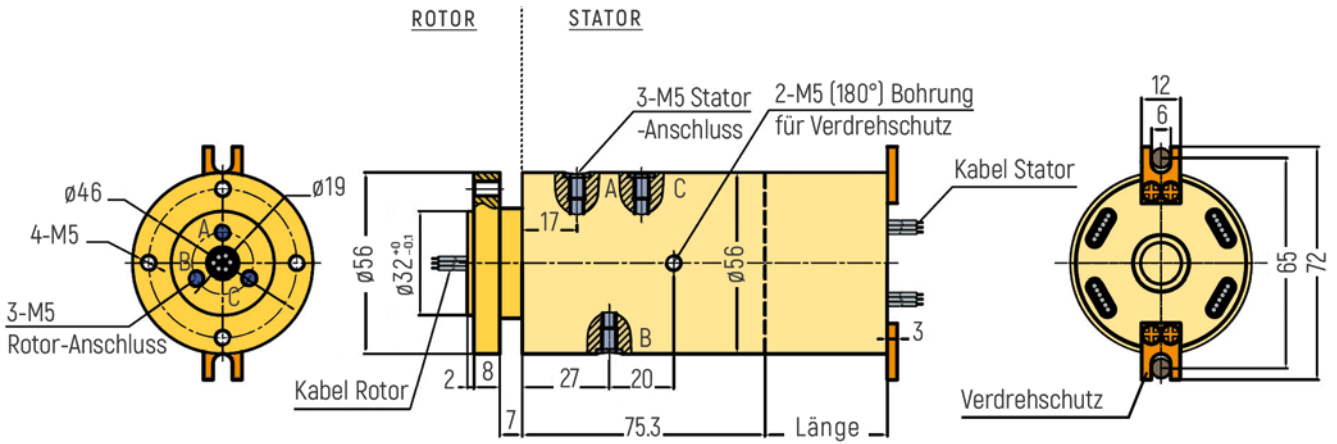

RX-PN1803-QS2-B - G1/8" Anschluss

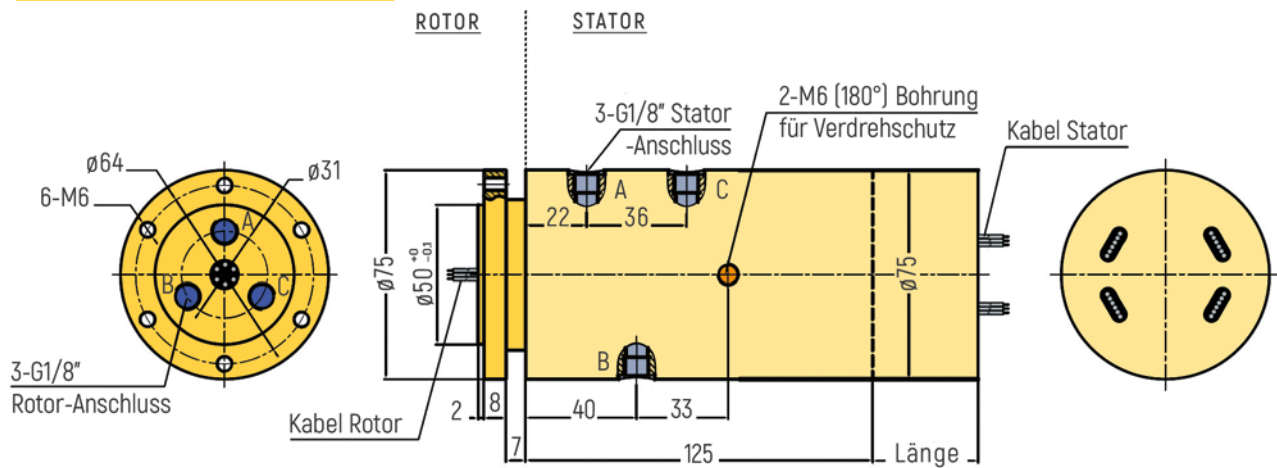

RX-PN1403-QS2-B - G1/4" Anschluss

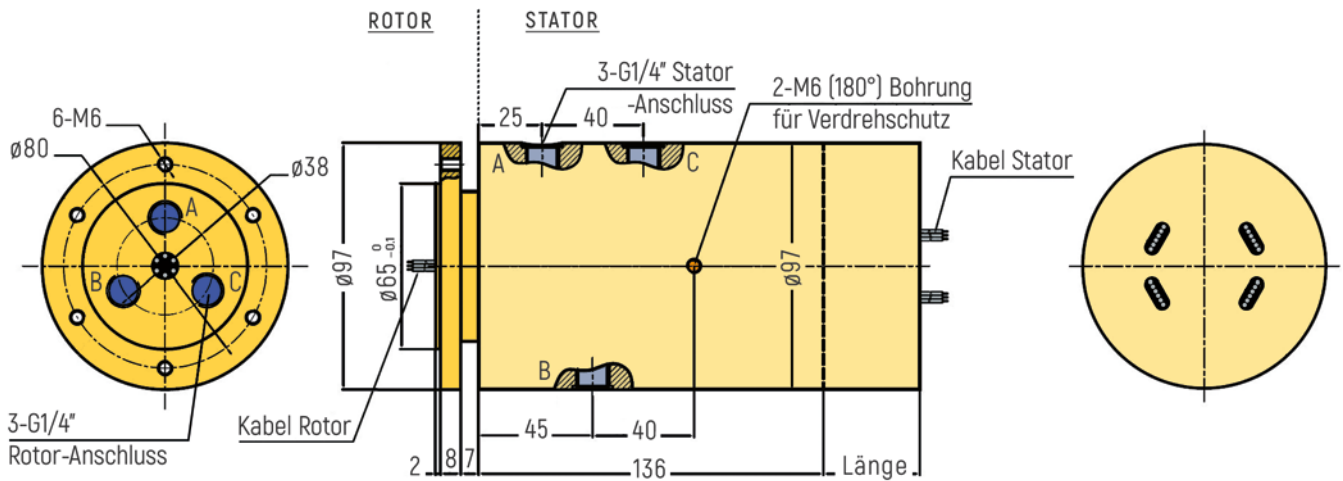

HYBRID-SCHLEIFRINGE PNEUMATIK + ELEKTRIK

ABMESSUNGEN (in mm)

RX-PN3803-QS2-B - G3/8" Anschluss

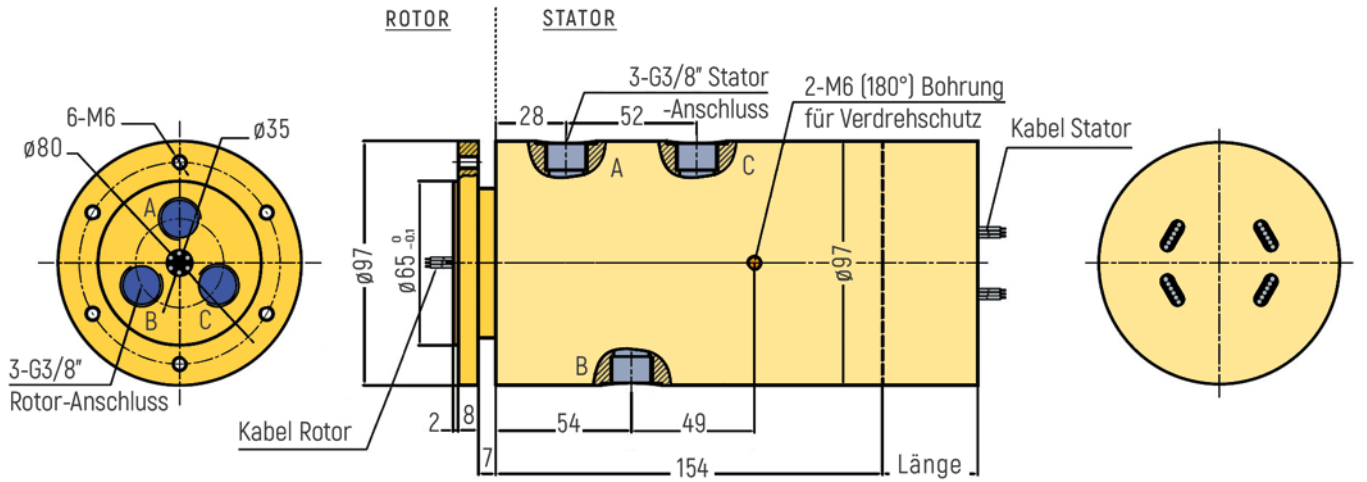

RX-PN1203-QS2-B - G1/2" Anschluss

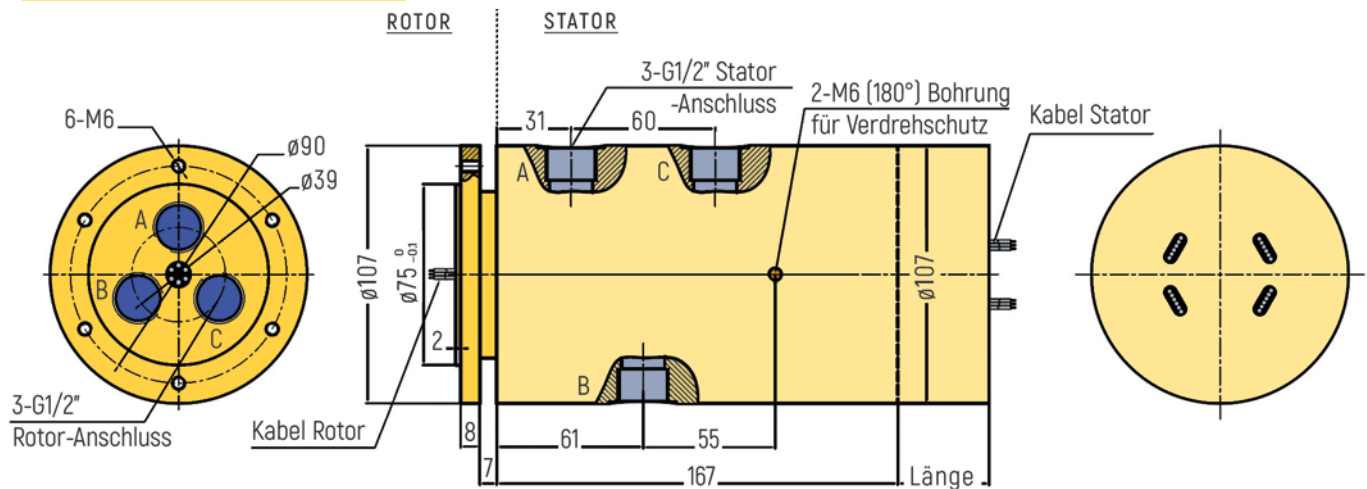

RX-PNM503-QS2-C - M5 Anschluss

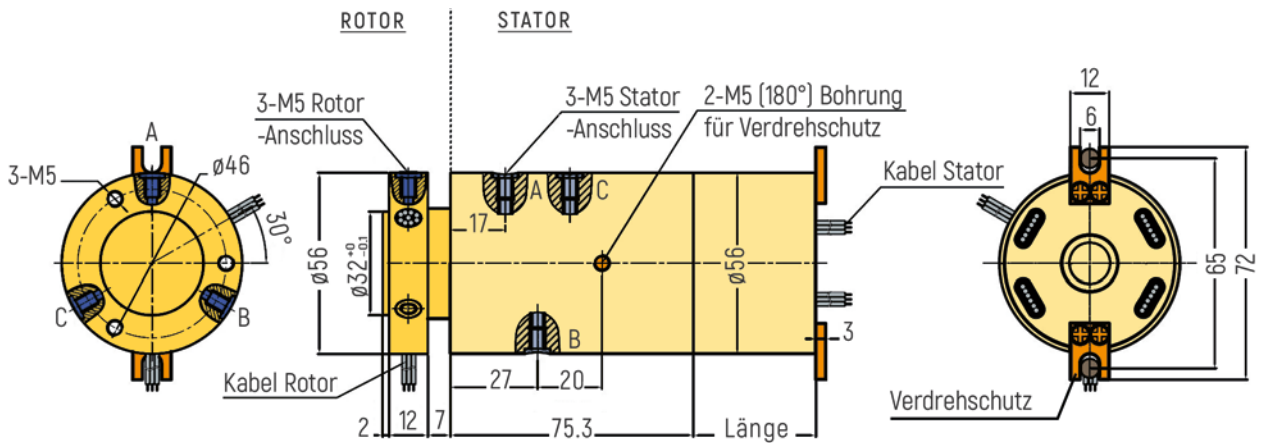

HYBRID-SCHLEIFRINGE PNEUMATIK + ELEKTRIK

ABMESSUNGEN (in mm)

RX-PN1803-QS2-C - G1/8" Anschluss

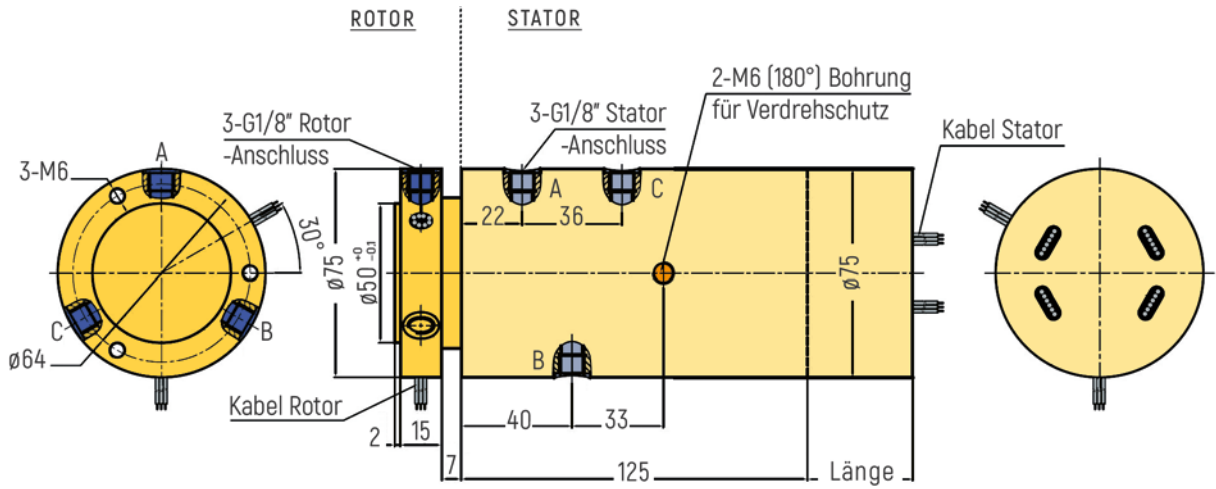

RX-PN1403-QS2-C - G1/4" Anschluss

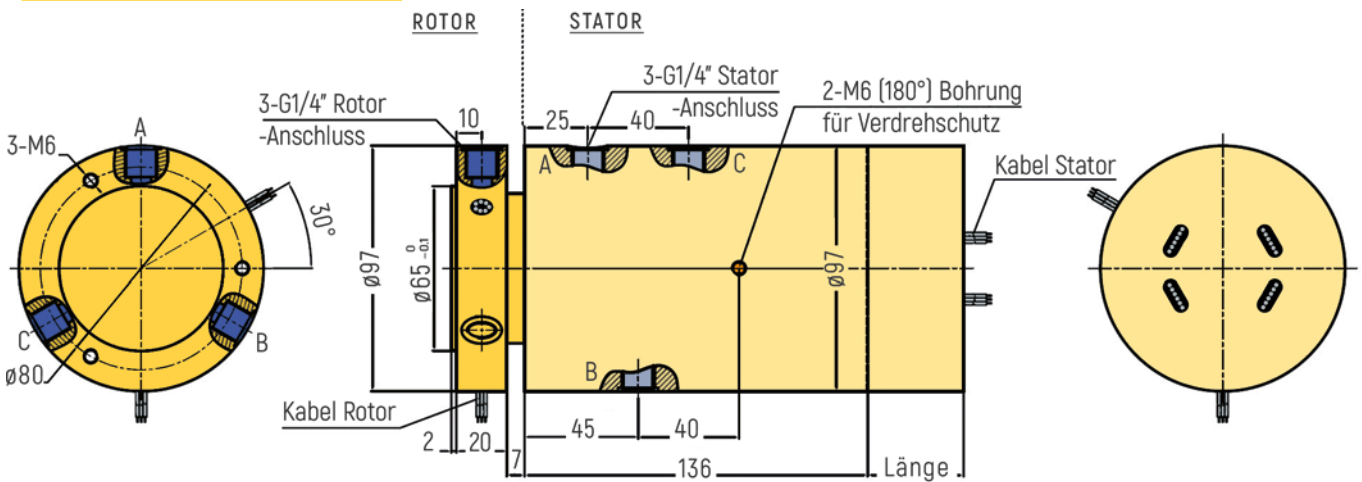

RX-PN3803-QS2-C - G3/8" Anschluss

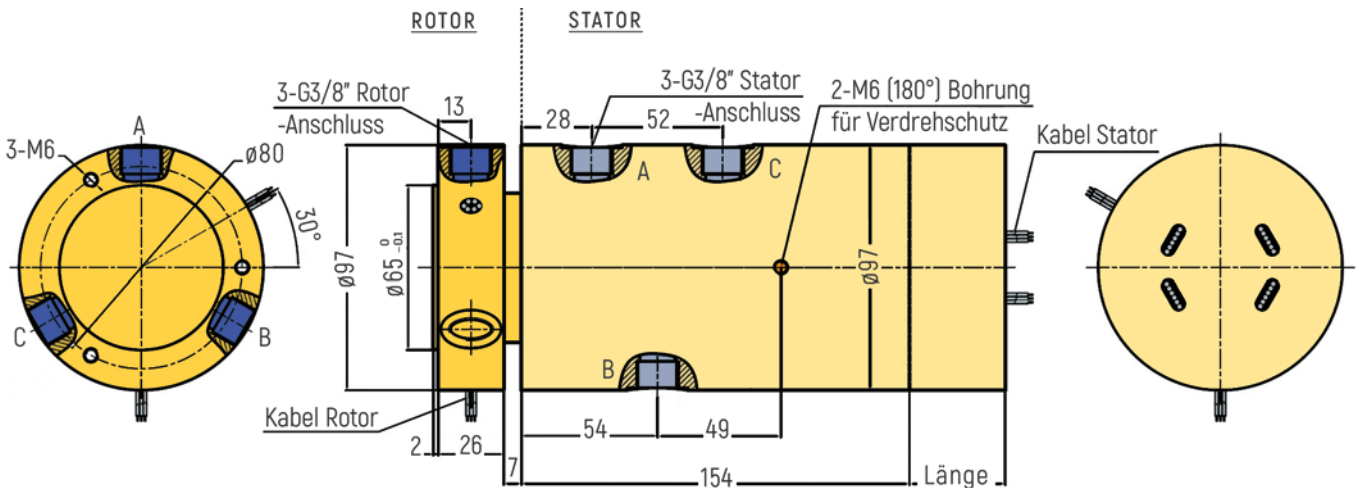

HYBRID-SCHLEIFRINGE PNEUMATIK + ELEKTRIK

ABMESSUNGEN (in mm)

RX-PN1203-QS2-C - G1/2" Anschluss

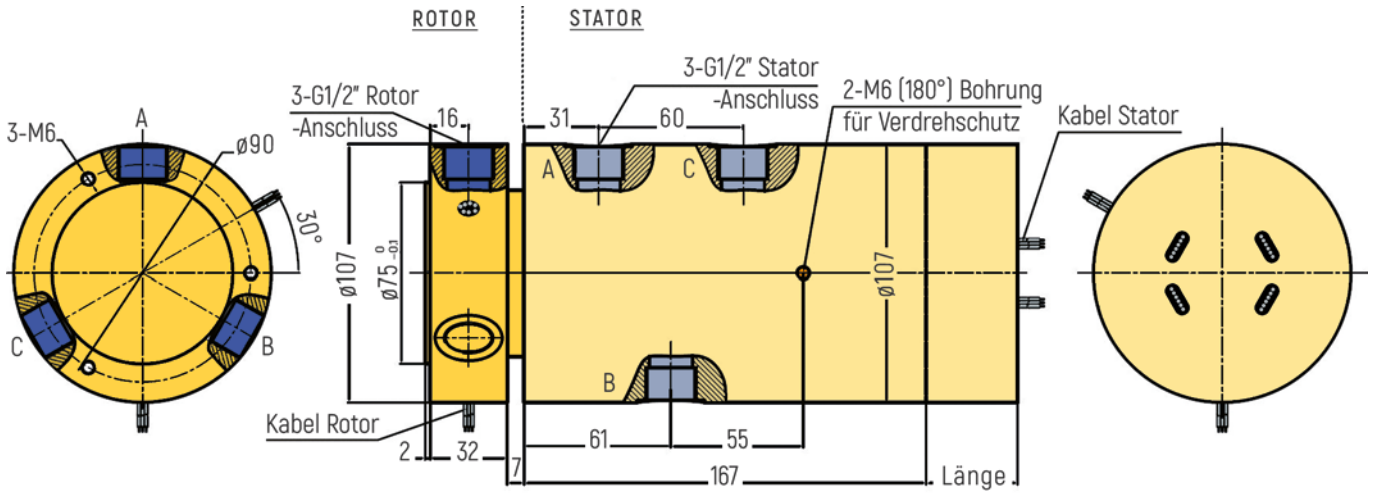

RX-PNM503-QS1-B - M5 Anschluss

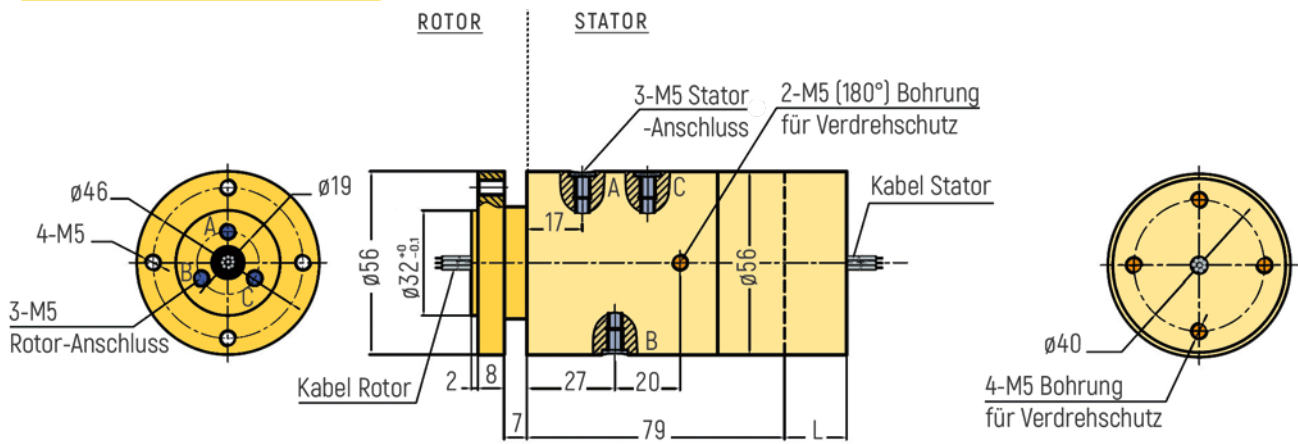

RX-PN1803-QS1-B - G1/8" Anschluss

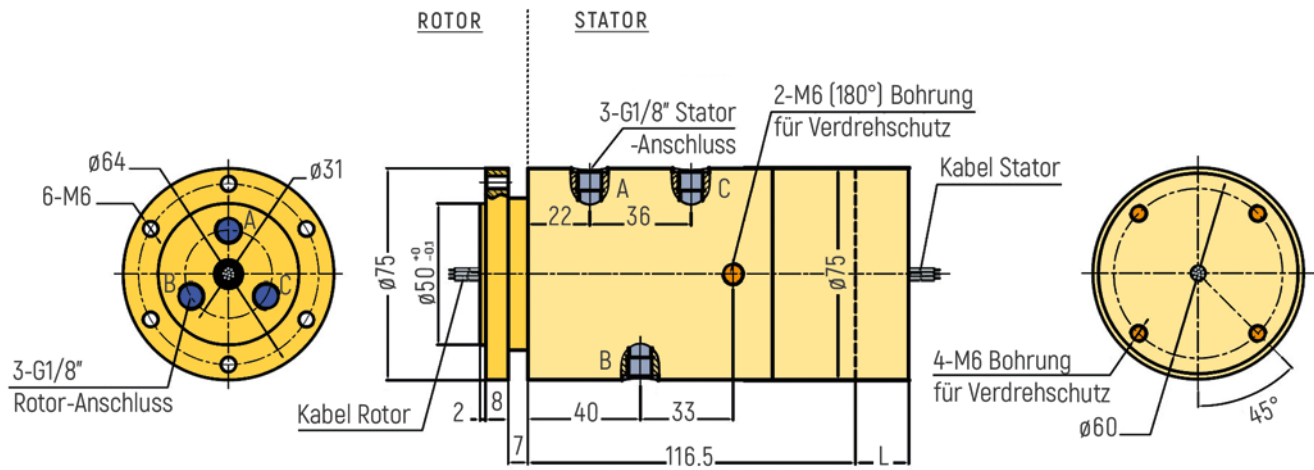

HYBRID-SCHLEIFRINGE PNEUMATIK + ELEKTRIK

ABMESSUNGEN (in mm)

RX-PN1403-QS1-B - G1/4" Anschluss

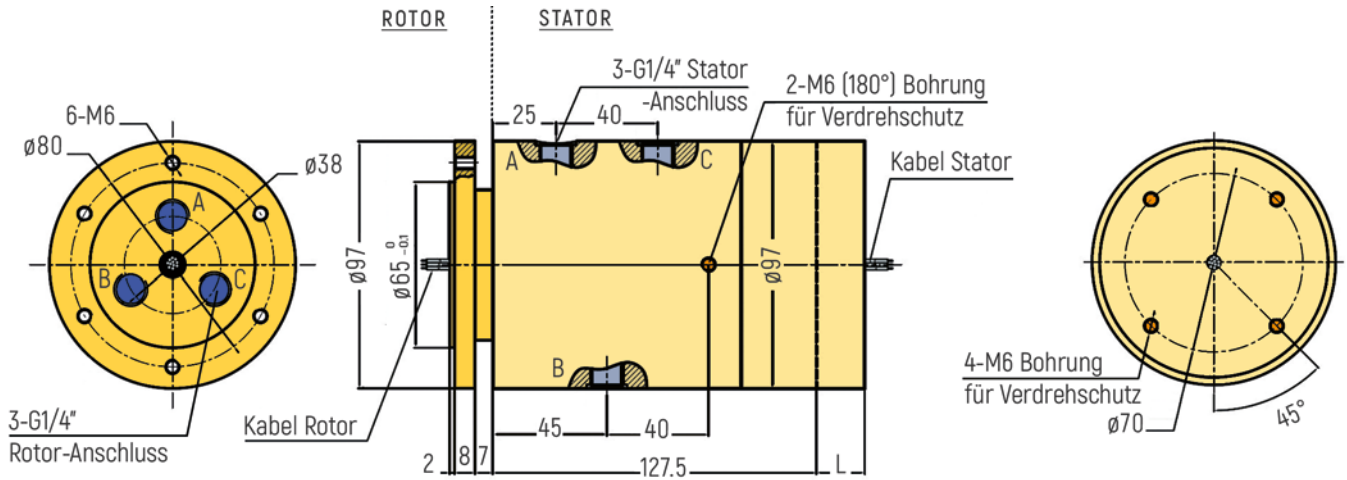

RX-PN3803-QS1-B - G3/8" Anschluss

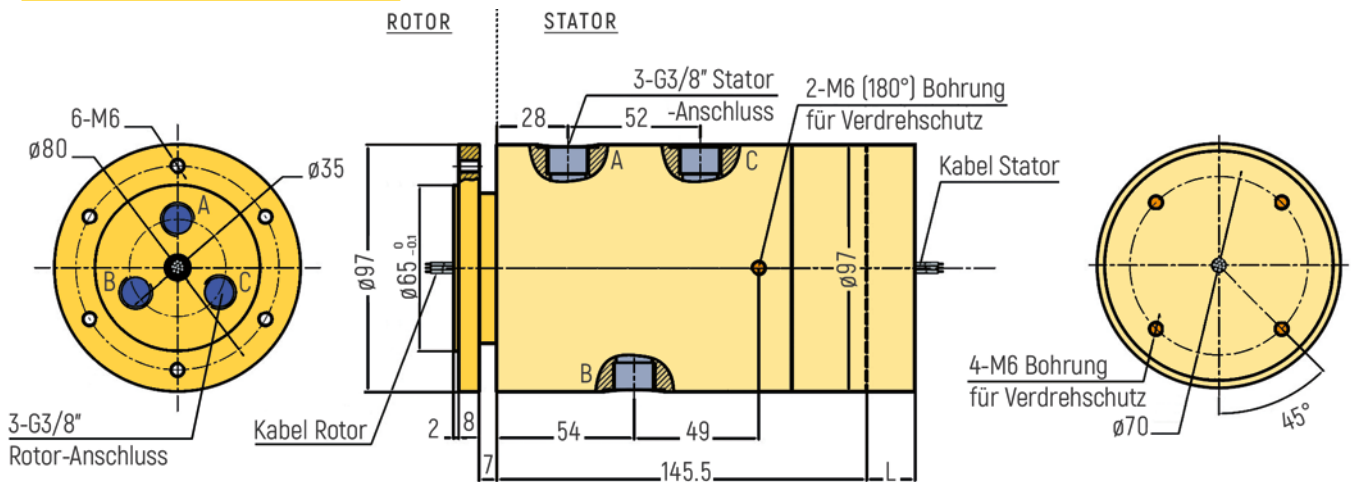

RX-PN1203-QS1-B - G1/2" Anschluss

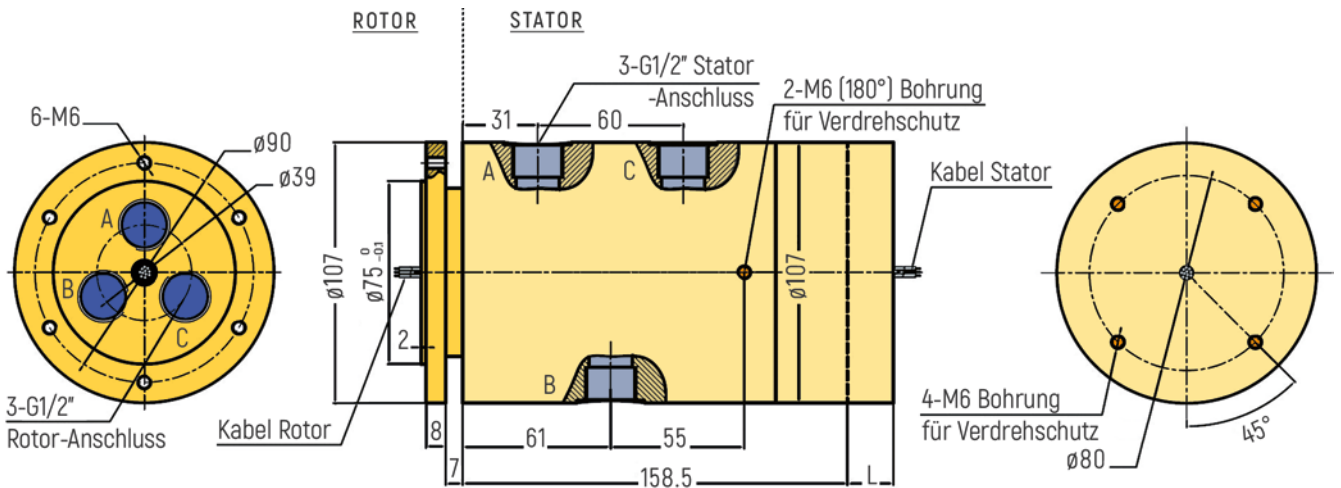

HYBRID-SCHLEIFRINGE PNEUMATIK + ELEKTRIK

ABMESSUNGEN (in mm)

RX-PNM504-QS2-B - M5 Anschluss

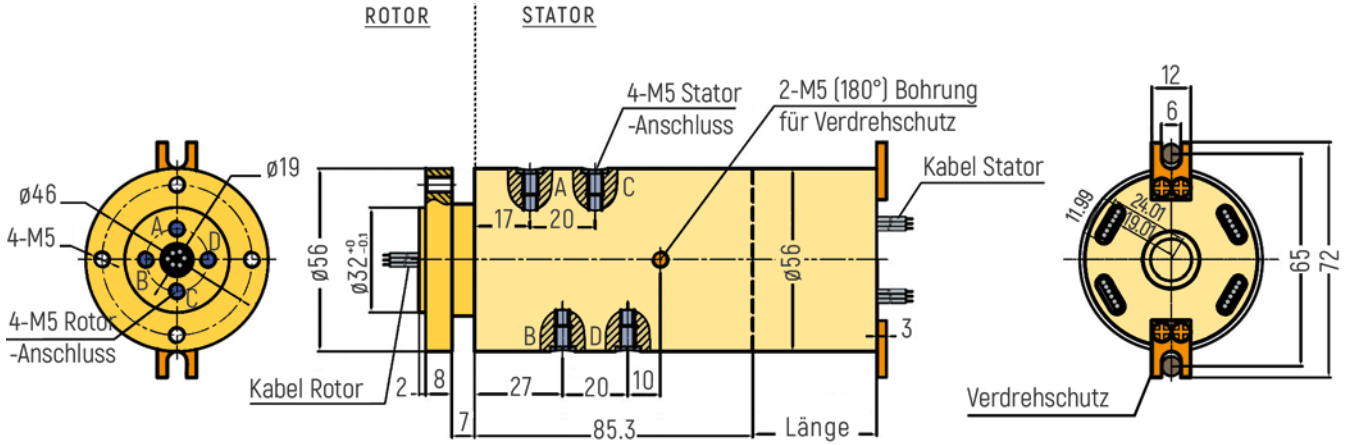

RX-PN1804-QS2-B - G1/8" Anschluss

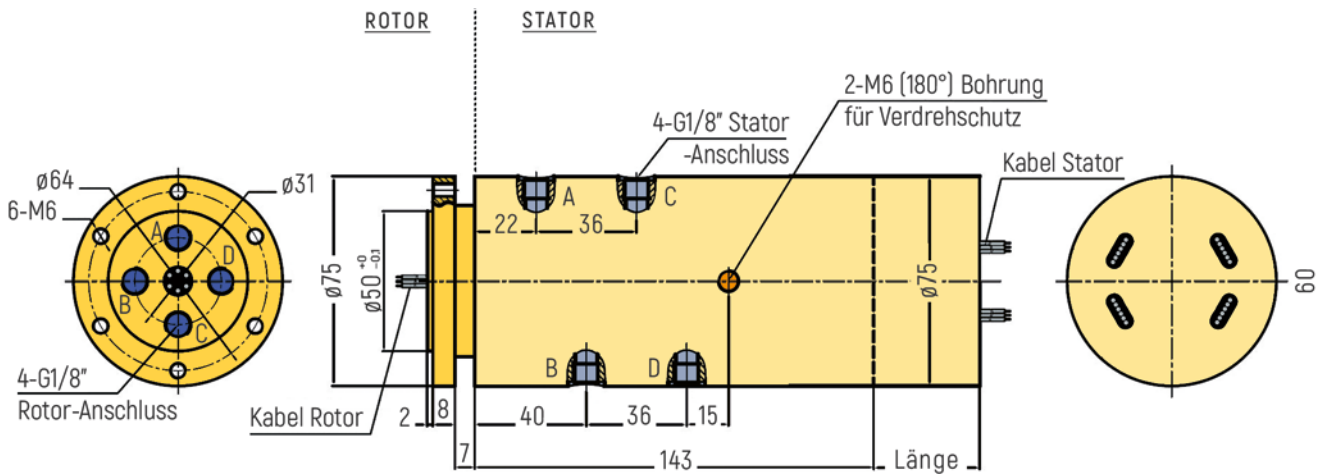

RX-PN1404-QS2-B - G1/4" Anschluss

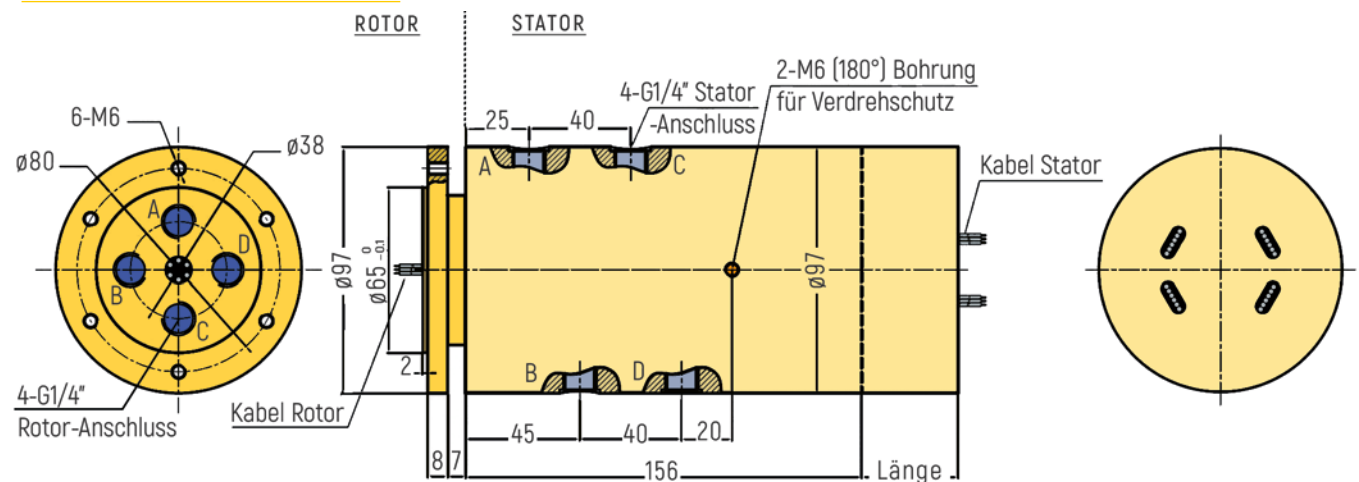

HYBRID-SCHLEIFRINGE PNEUMATIK + ELEKTRIK

ABMESSUNGEN (in mm)

RX-PN3804-QS2-B - G3/8" Anschluss

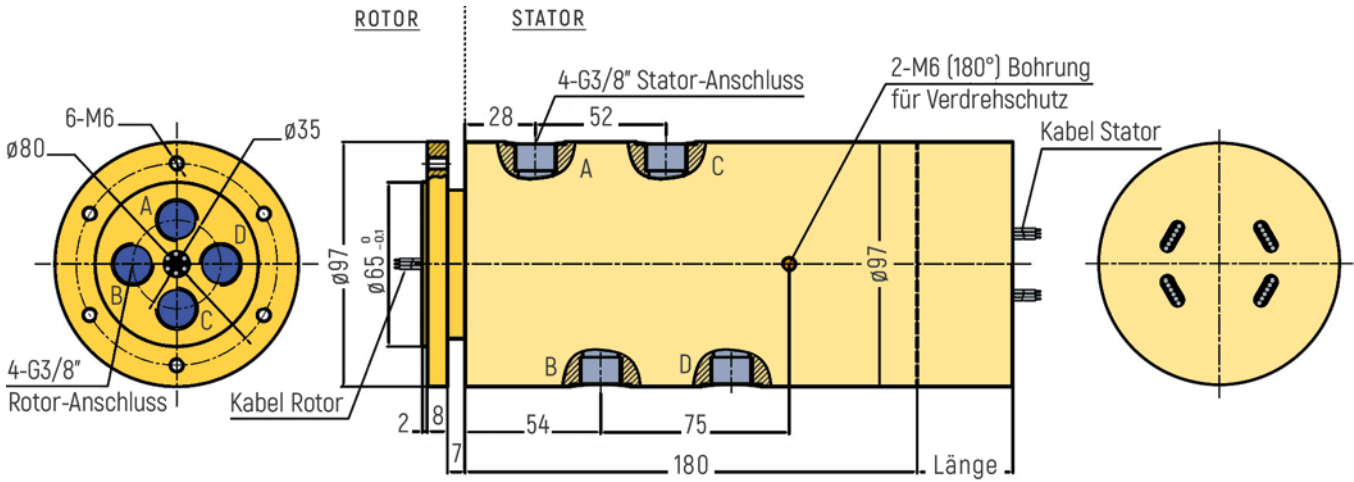

RX-PN1204-QS2-B - G1/2" Anschluss

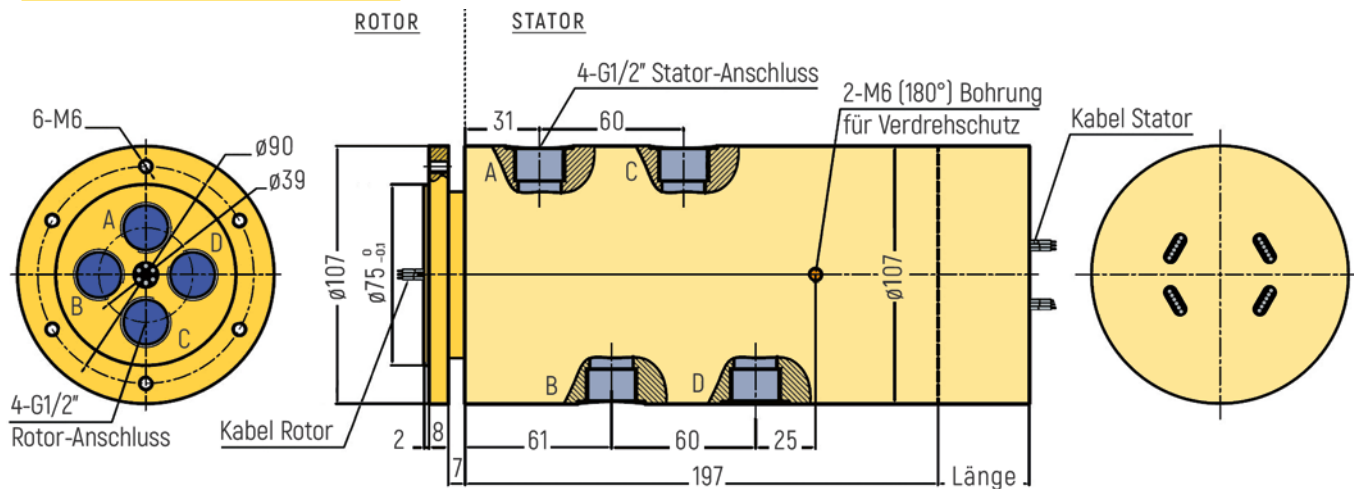

RX-PNM504-QS2-C - M5 Anschluss

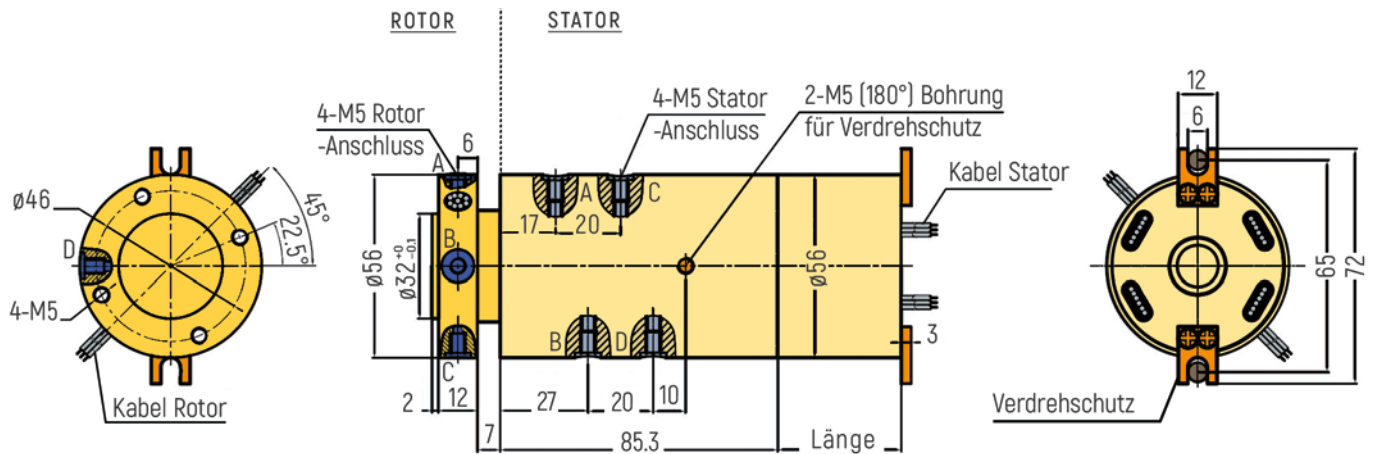

HYBRID-SCHLEIFRINGE PNEUMATIK + ELEKTRIK

ABMESSUNGEN (in mm)

RX-PN1804-QS2-C - G1/8" Anschluss

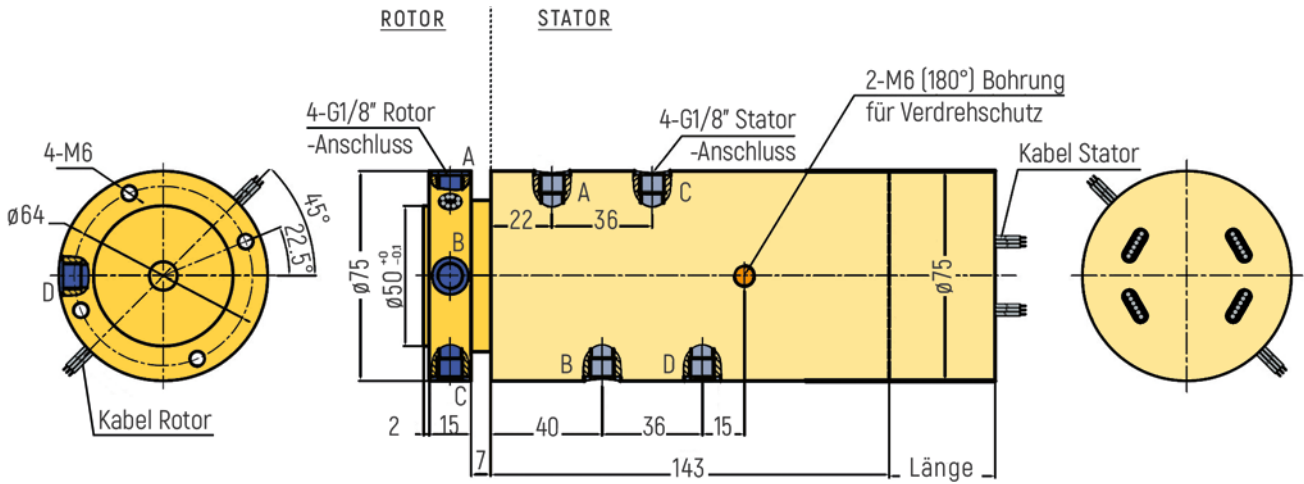

RX-PN1404-QS2-C - G1/4" Anschluss

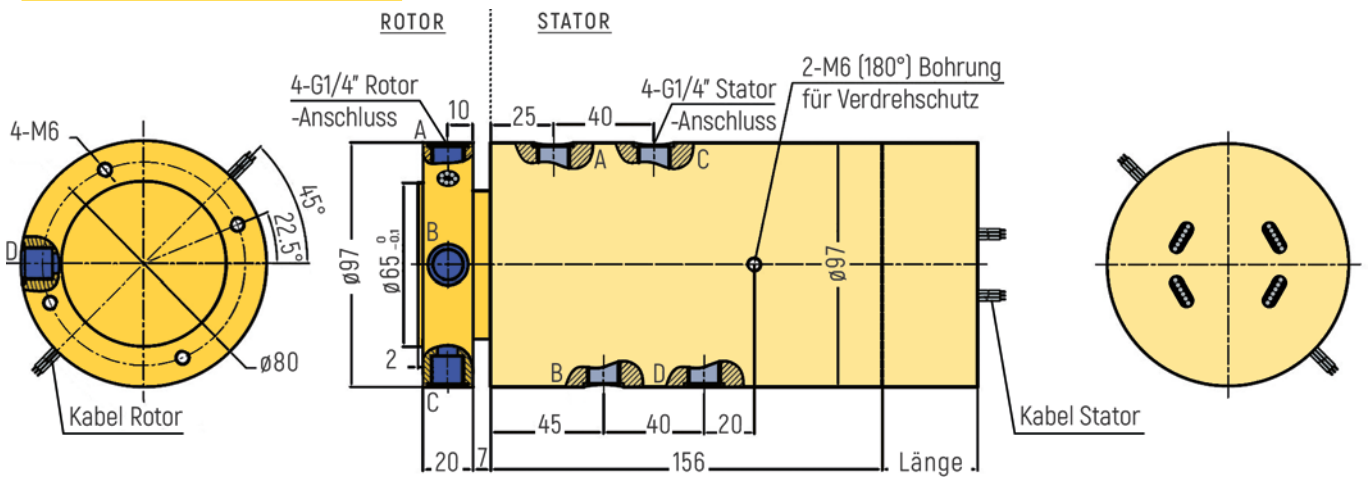

RX-PN3804-QS2-C - G3/8" Anschluss

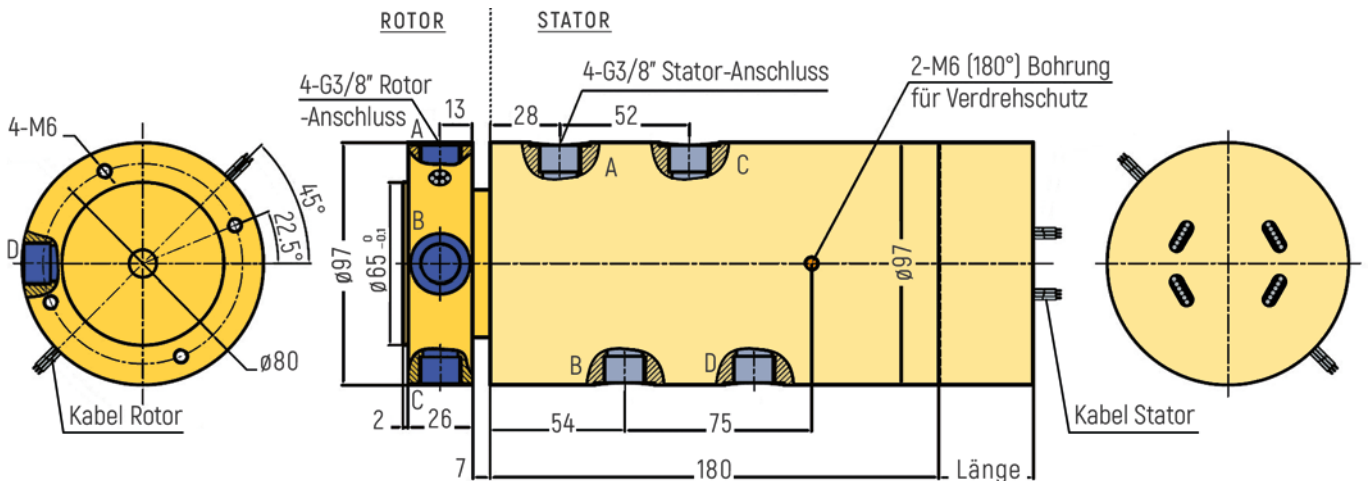

HYBRID-SCHLEIFRINGE PNEUMATIK + ELEKTRIK

ABMESSUNGEN (in mm)

RX-PN1204-QS2-C - G1/2" Anschluss

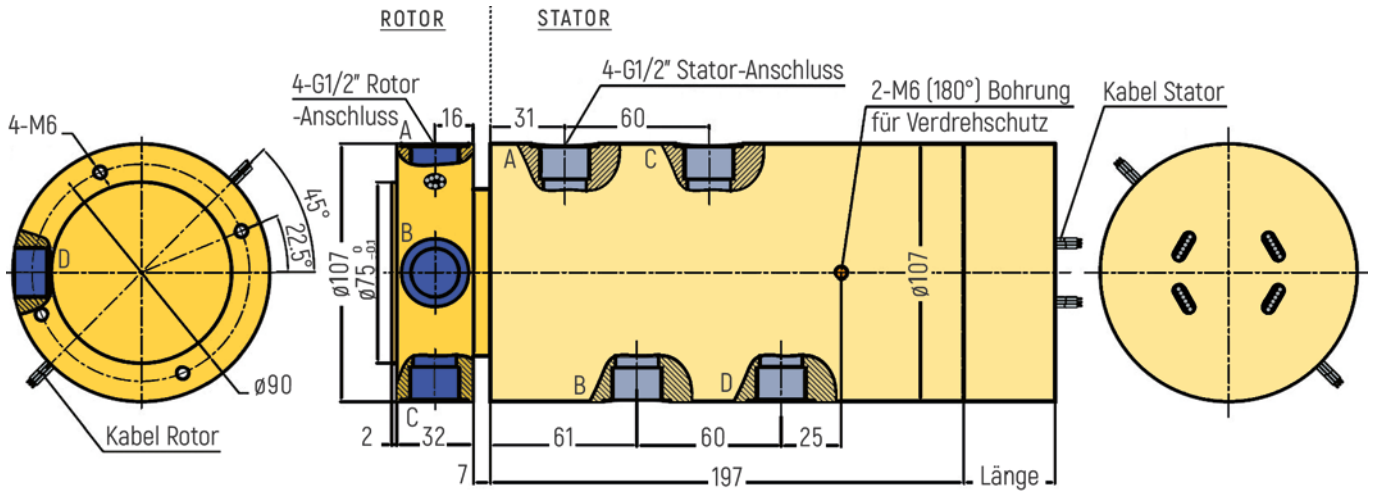

RX-PNM504-QS1-B - M5 Anschluss

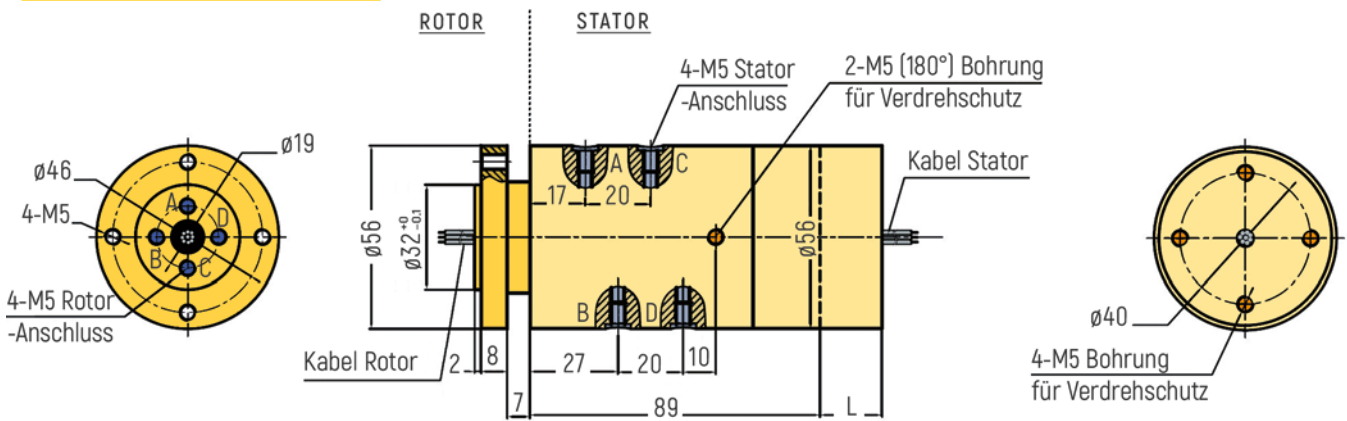

RX-PN1804-QS1-B - G1/8" Anschluss

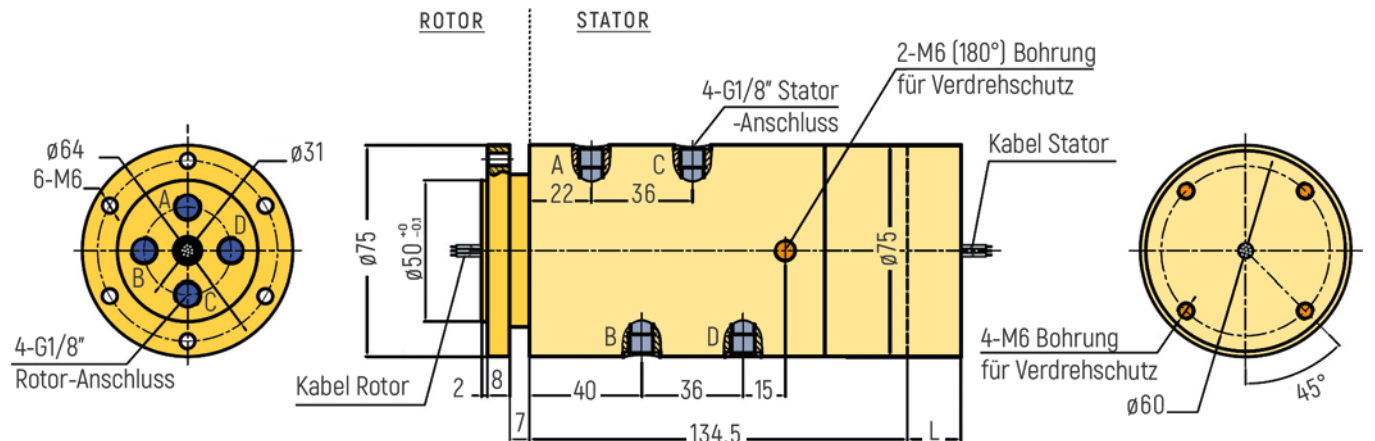

HYBRID-SCHLEIFRINGE PNEUMATIK + ELEKTRIK

ABMESSUNGEN (in mm)

RX-PN1404-QS1-B - G1/4" Anschluss

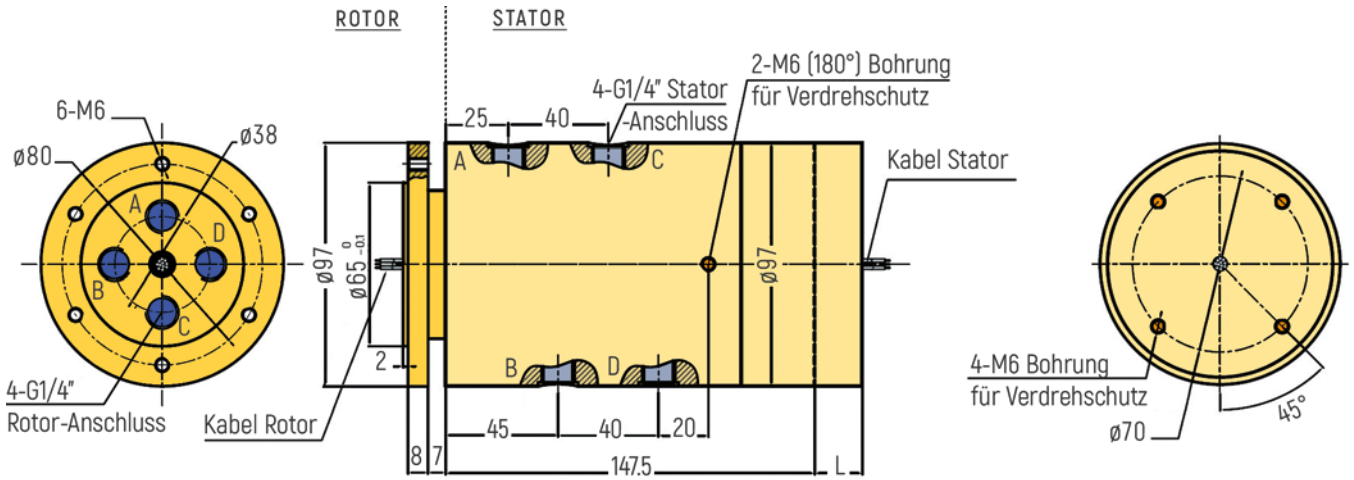

RX-PN3804-QS1-B - G3/8" Anschluss

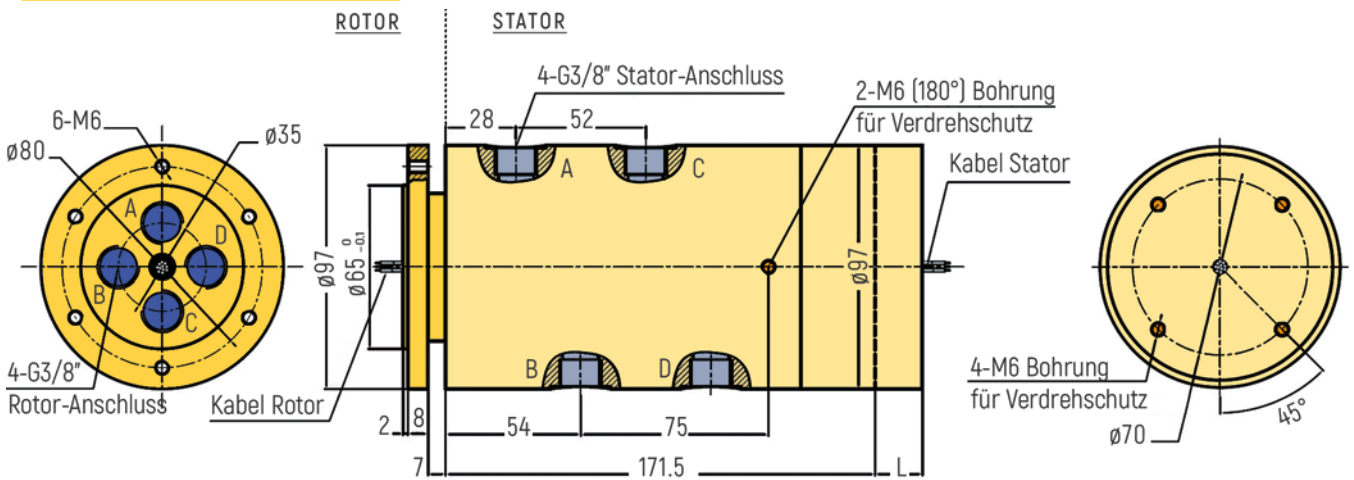

RX-PN1204-QS1-B - G1/2" Anschluss

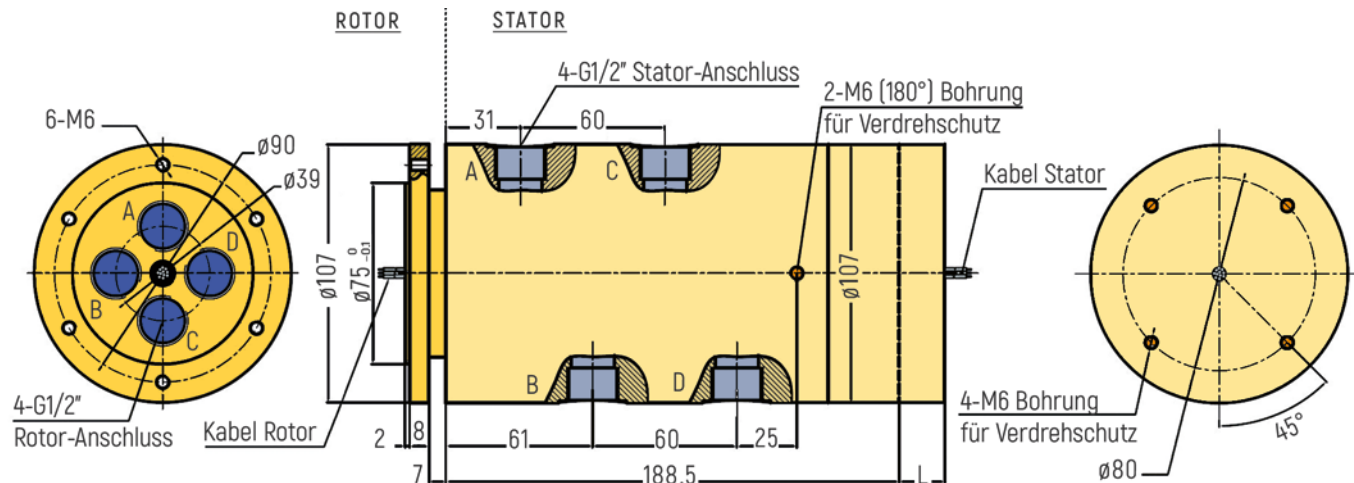

HYBRID-SCHLEIFRINGE PNEUMATIK + ELEKTRIK

ABMESSUNGEN (in mm)

RX-PN1804-QS2-D - G1/8" Anschluss

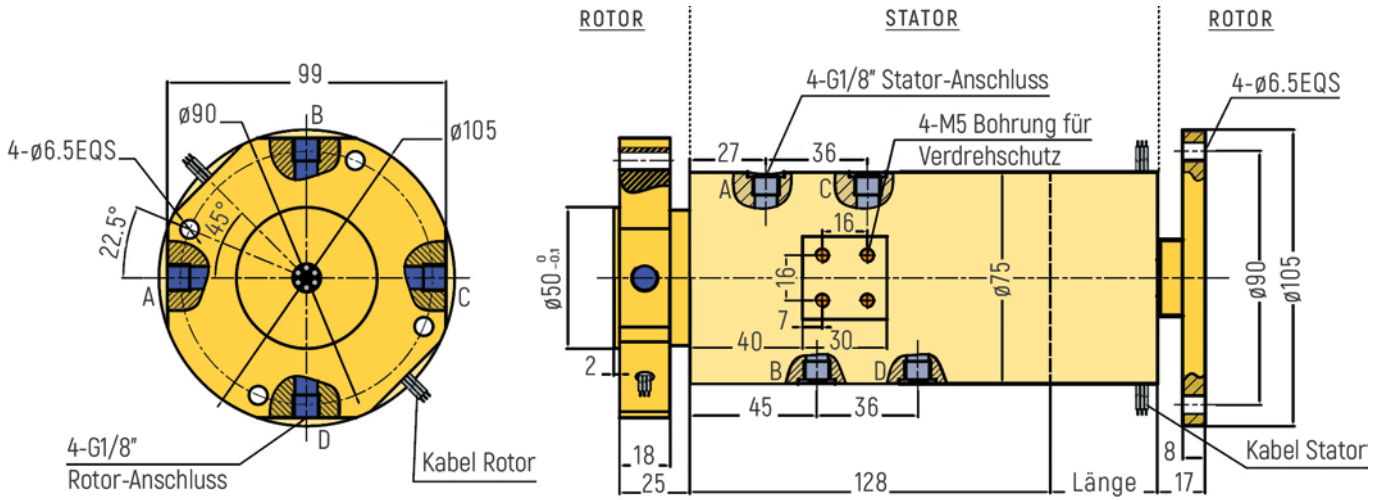

RX-PN1404-QS2-D - G1/4" Anschluss

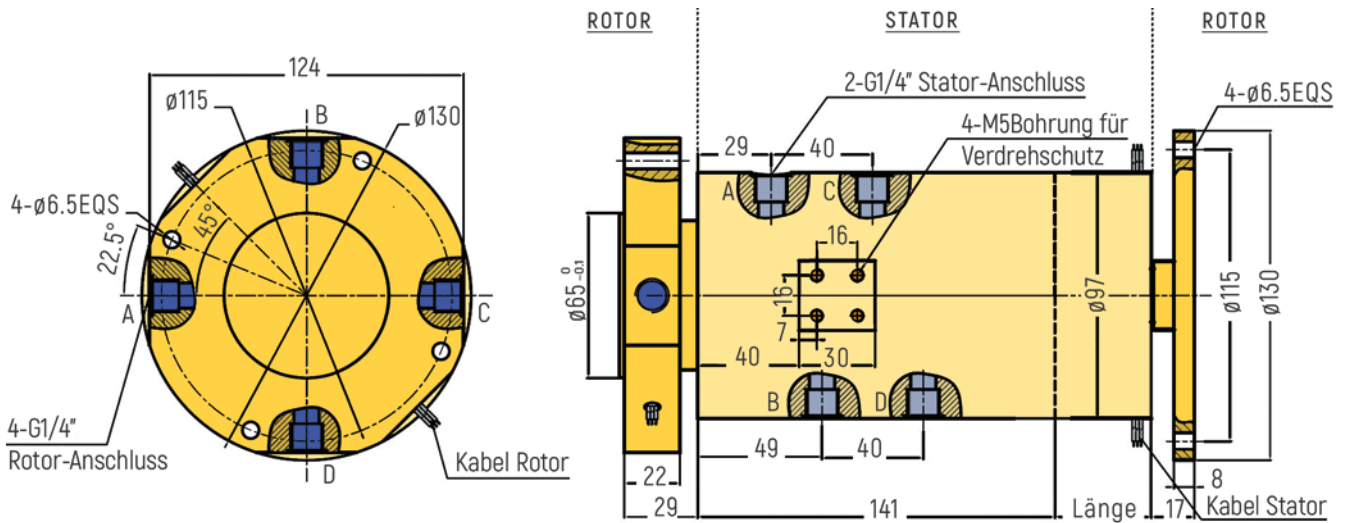

HYBRID-SCHLEIFRINGE PNEUMATIK + ELEKTRIK

ABMESSUNGEN (in mm)

RX-PNM506-QS2-B - M5 Anschluss

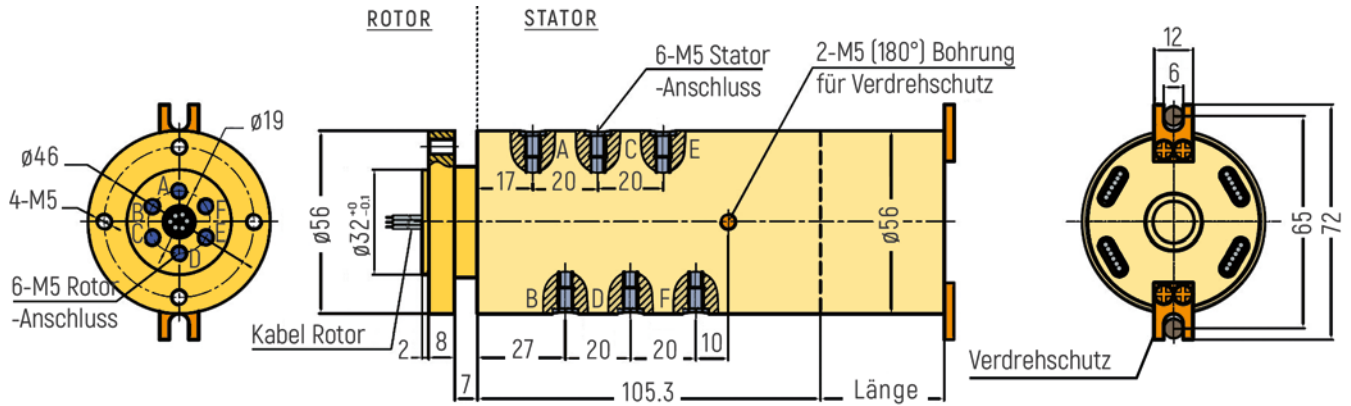

RX-PN1806-QS2-B - G1/8" Anschluss

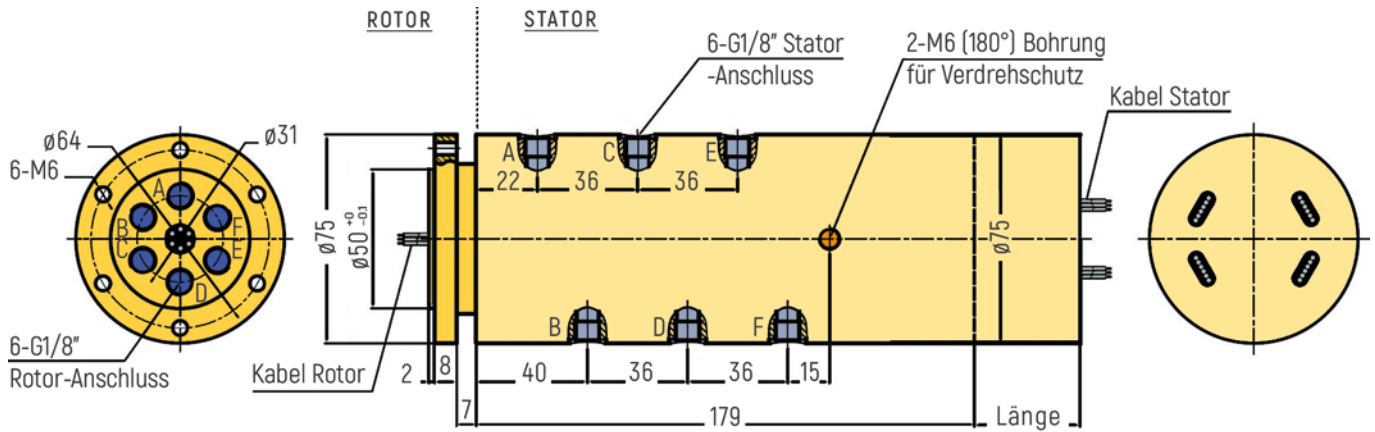

RX-PN1406-QS2-B - G1/4" Anschluss

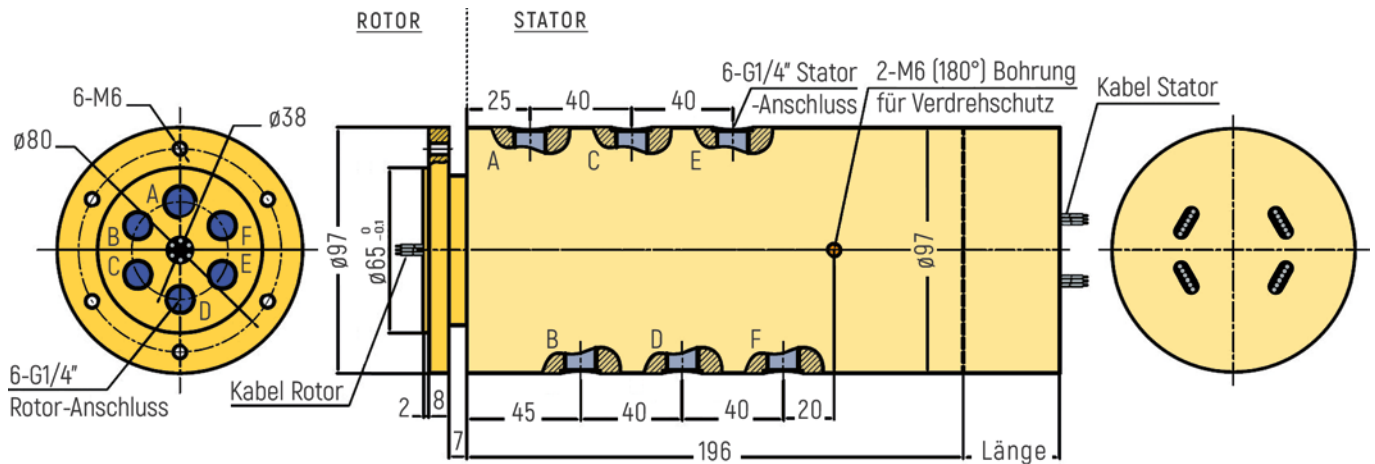

HYBRID-SCHLEIFRINGE PNEUMATIK + ELEKTRIK

ABMESSUNGEN (in mm)

RX-PNM506-QS2-C - M5 Anschluss

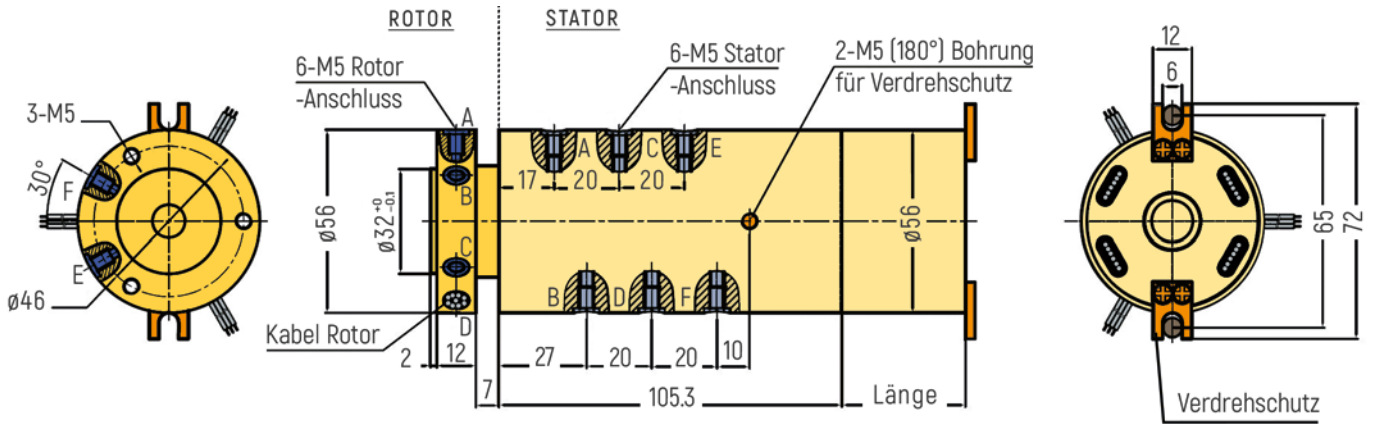

RX-PN1806-QS2-C - G1/8" Anschluss

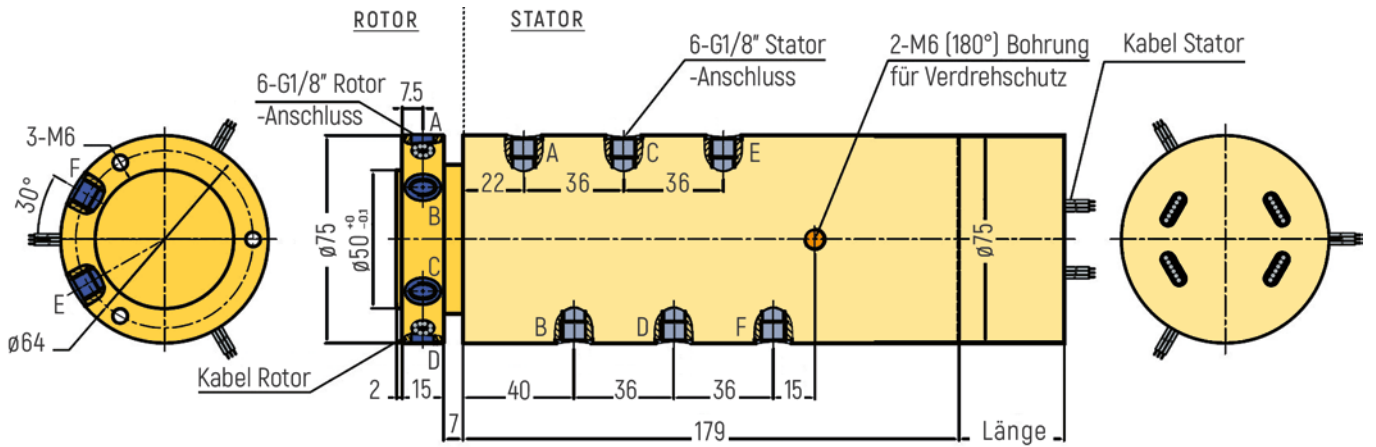

RX-PN1406-QS2-C - G1/4" Anschluss

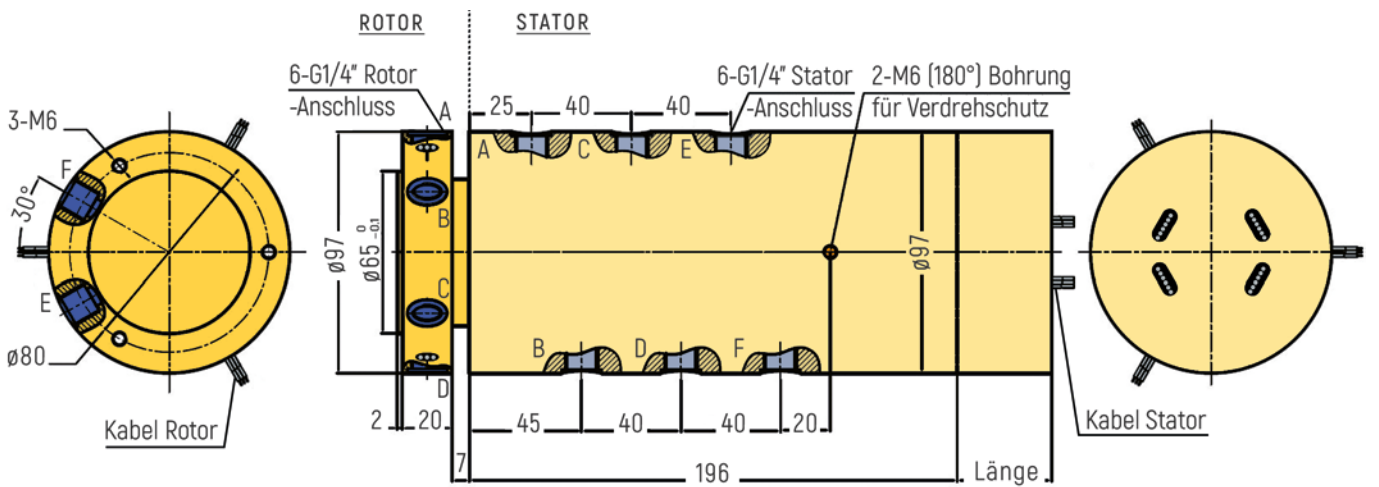

HYBRID-SCHLEIFRINGE PNEUMATIK + ELEKTRIK

ABMESSUNGEN (in mm)

RX-PNM506-QS1-B - M5 Anschluss

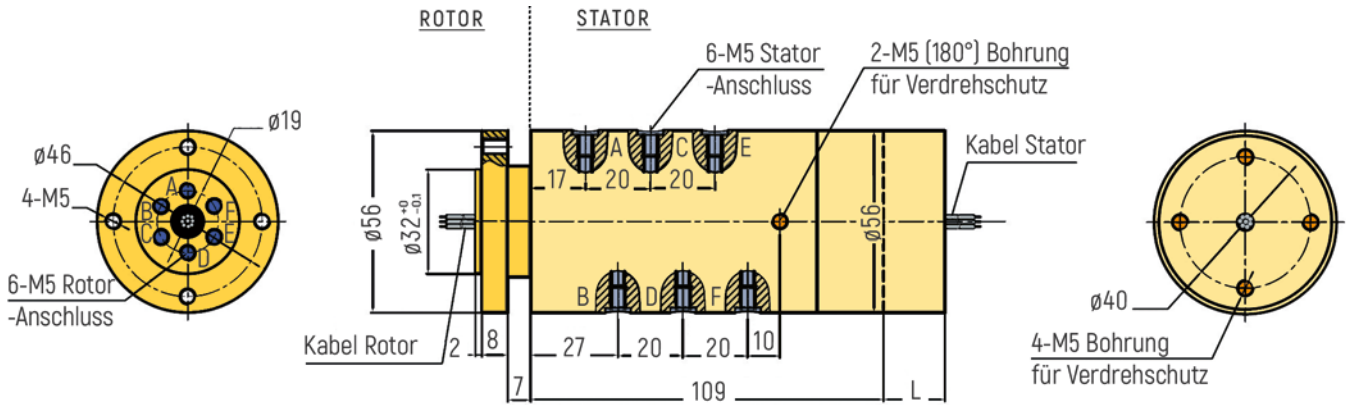

RX-PN1806-QS1-B - G1/8" Anschluss

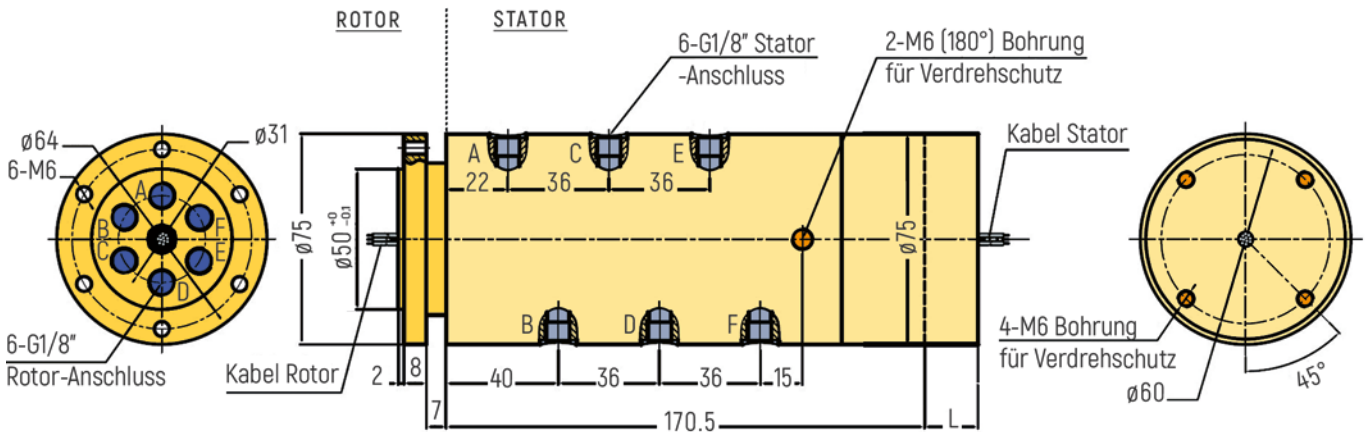

RX-PN1406-QS1-B - G1/4" Anschluss

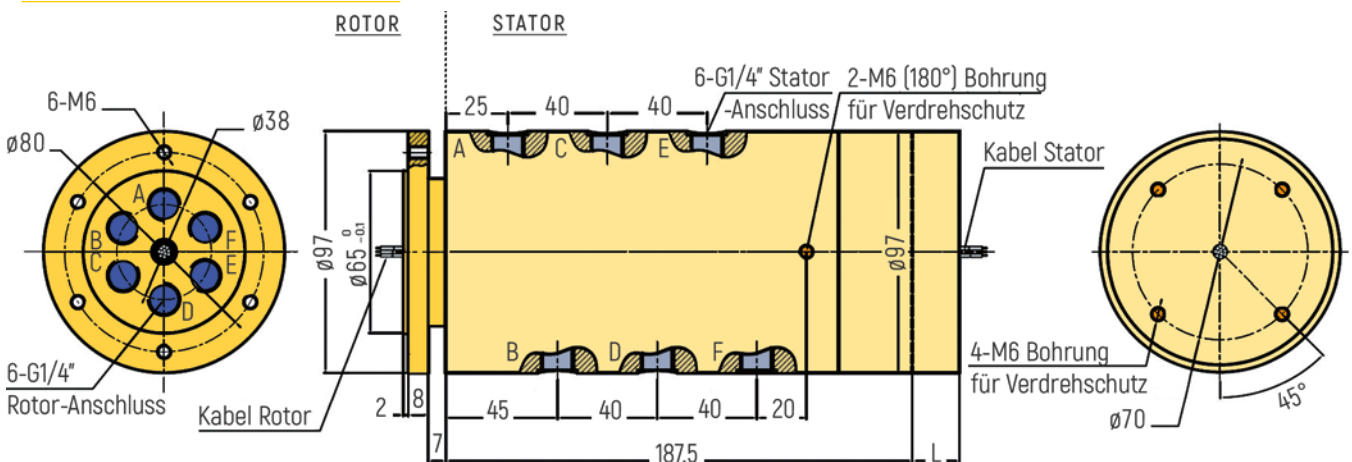

HYBRID-SCHLEIFRINGE PNEUMATIK + ELEKTRIK

ABMESSUNGEN (in mm)

RX-PNM508-QS2-B - M5 Anschluss

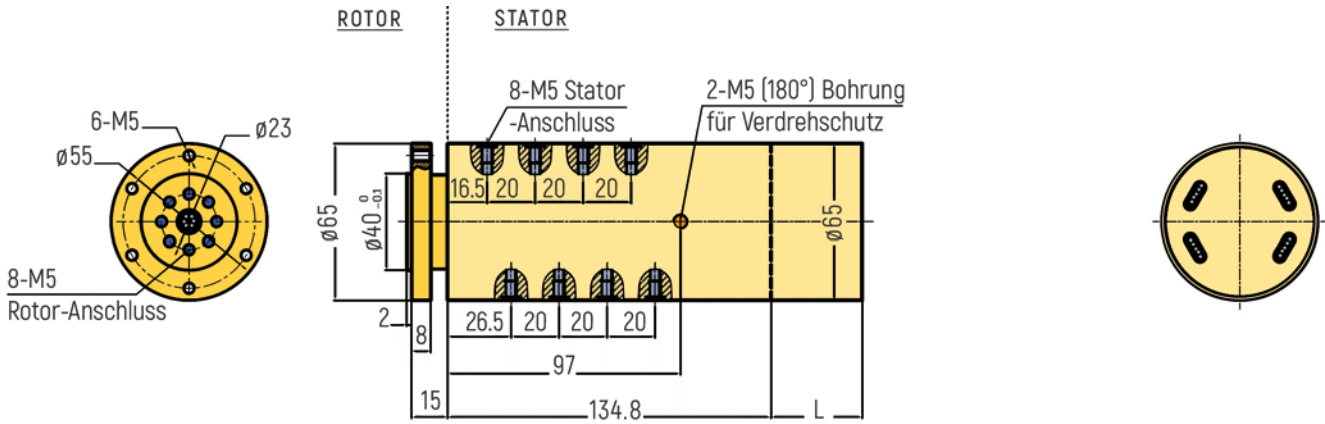

RX-PN1808-QS2-B - G1/8" Anschluss

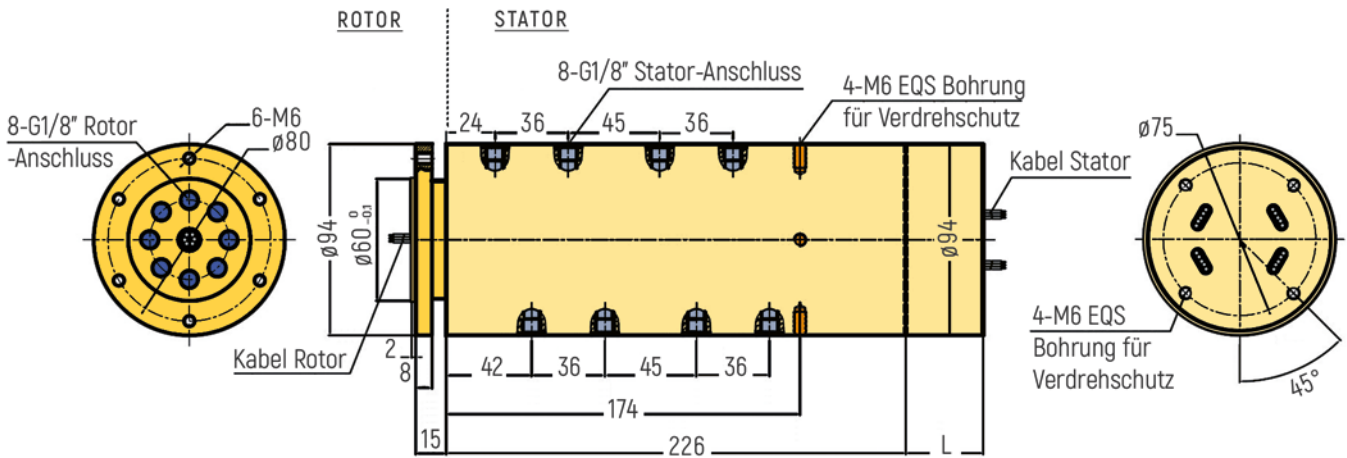

RX-PN1408-QS2-B - G1/4" Anschluss

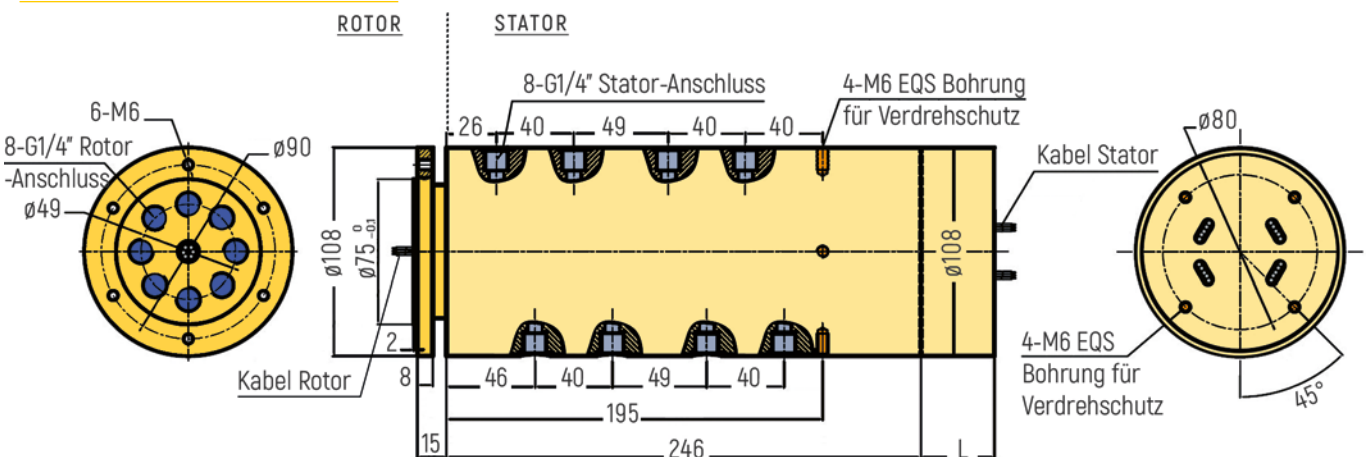

HYBRID-SCHLEIFRINGE PNEUMATIK + ELEKTRIK

ABMESSUNGEN (in mm)

RX-PNM510-QS2-B - M5 Anschluss

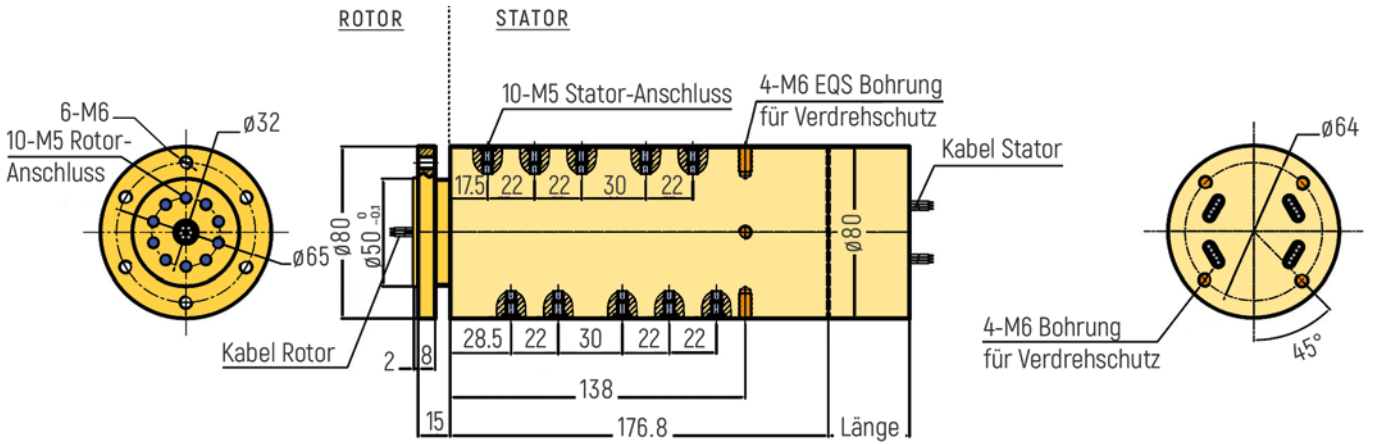

RX-PNM512-QS2-B - M5 Anschluss

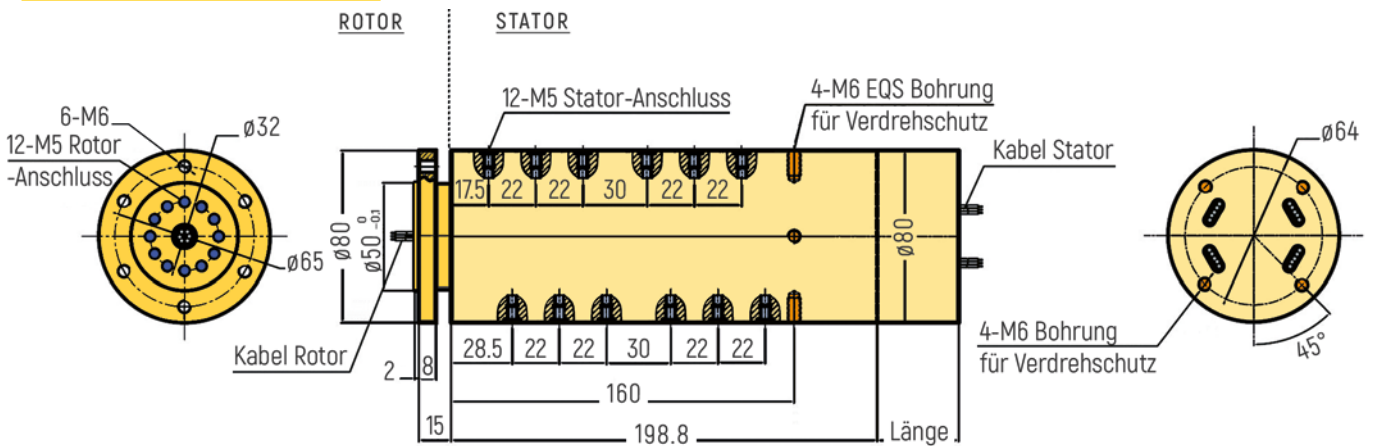

RX-PNM516-QS2-B - M5 Anschluss

