

# MINIATUR PNEUMATIK

RX-PMM501 Serie	p.1	RX-PMM503 Serie	p.3
RX-PMM502 Serie	p.2	RX-PMM504 Serie	p.4

**ABMESSUNGEN (in mm)**

RX-PMM501 - Keine Signalinge

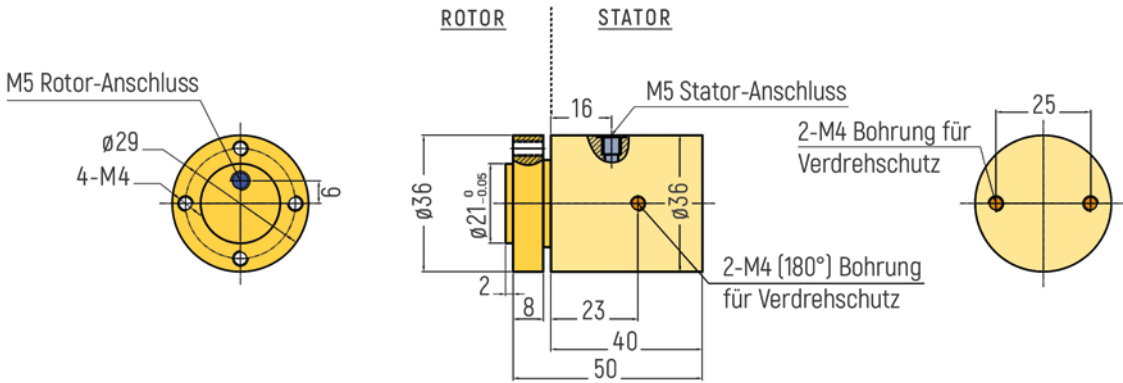

RX-PMM501 - 6 Signalinge

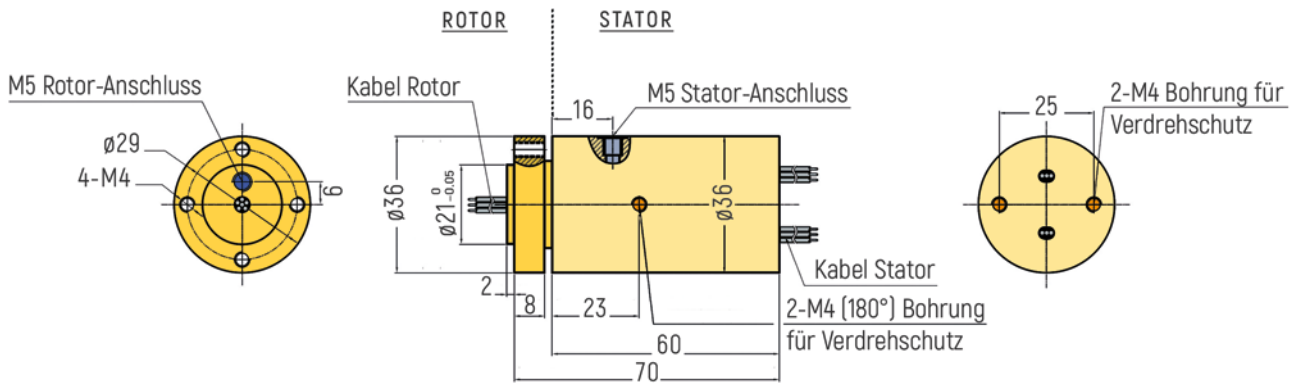

RX-PMM501 - 12 Signalinge

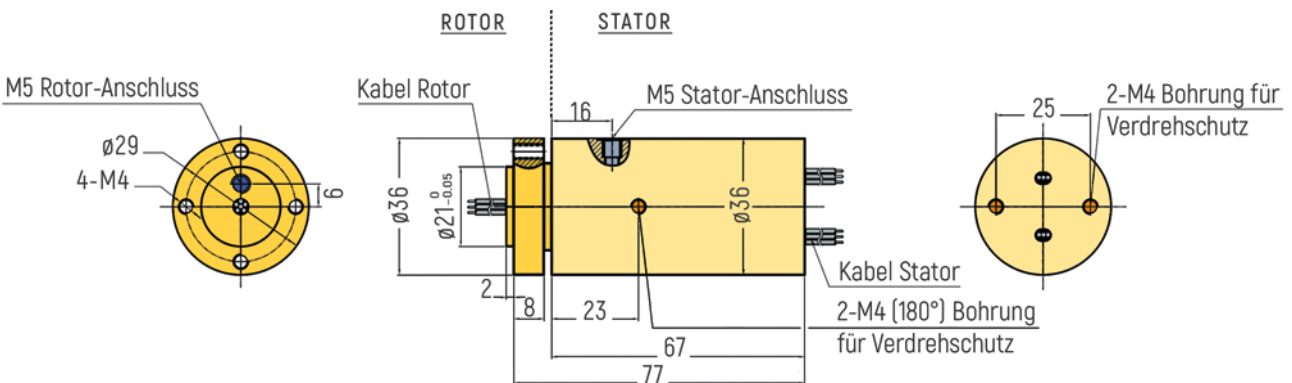

# MINIATUR PNEUMATIK



ABMESSUNGEN (in mm)

RX-PM502 - Keine Signalinge

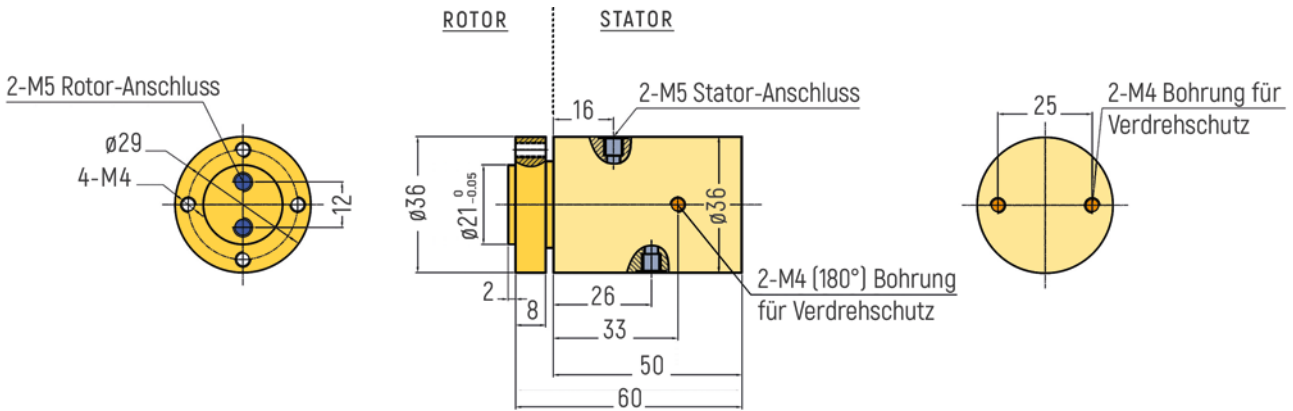

RX-PM502 - 6 Signalinge

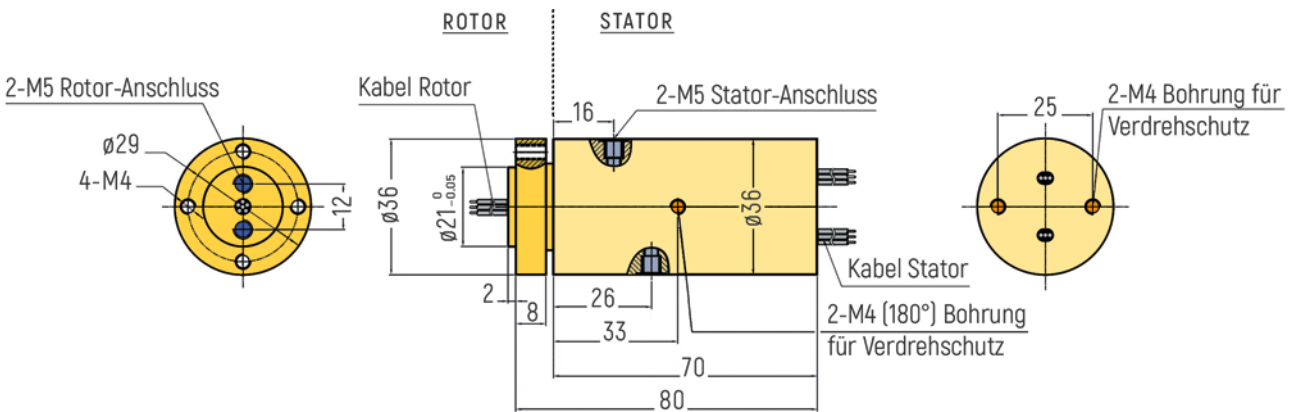

RX-PM502 - 12 Signalinge

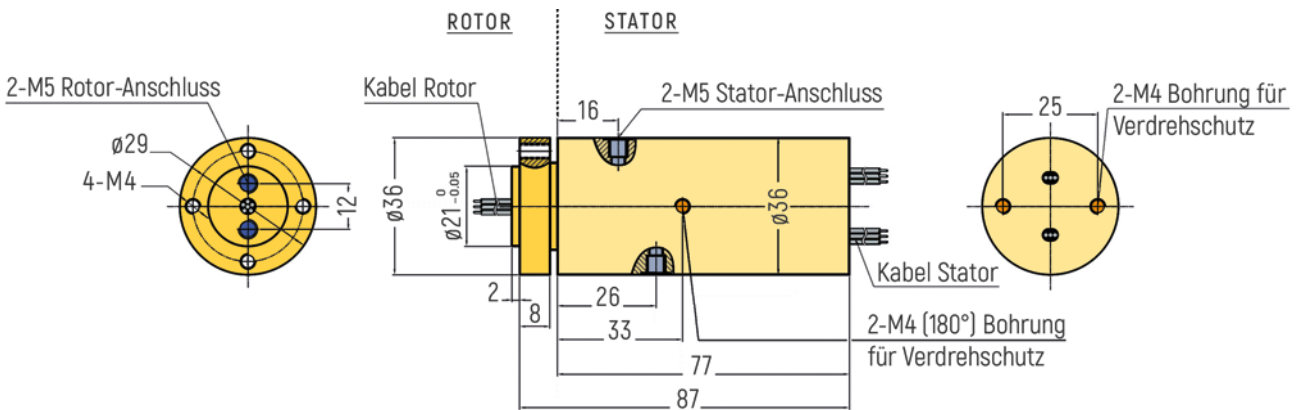

# MINIATUR PNEUMATIK



ABMESSUNGEN (in mm)

RX-PM503 - Keine Signalinge

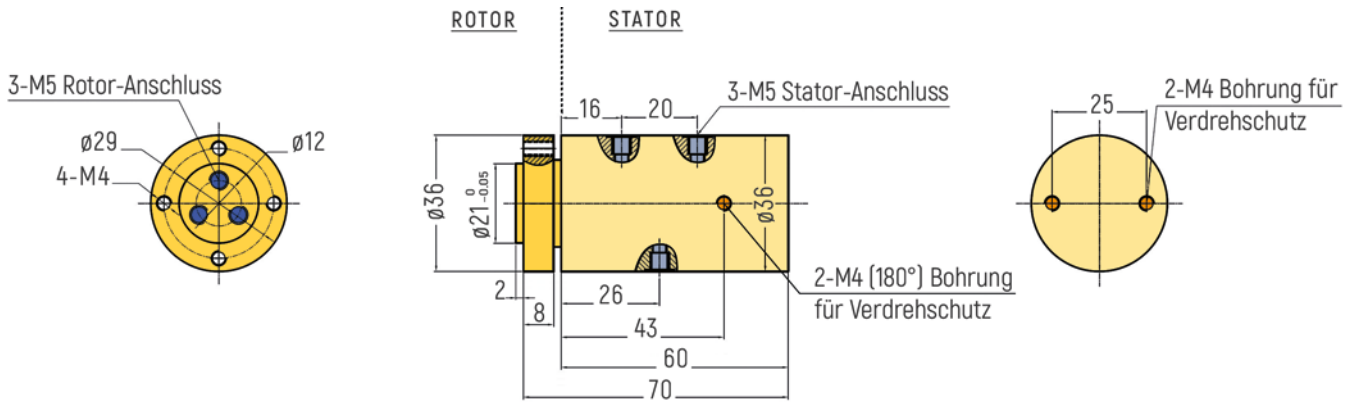

RX-PM503 - 6 Signalinge

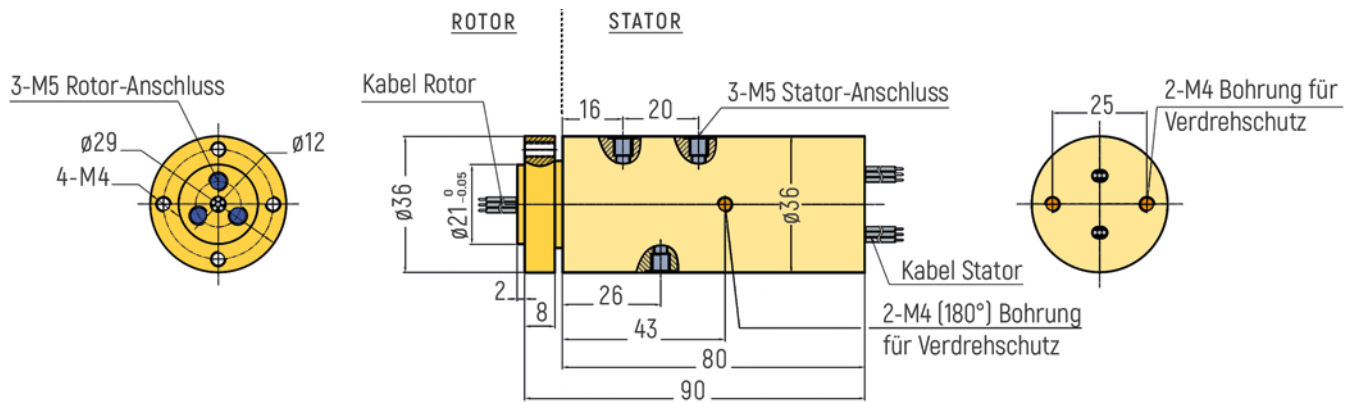

RX-PM503 - 12 Signalinge

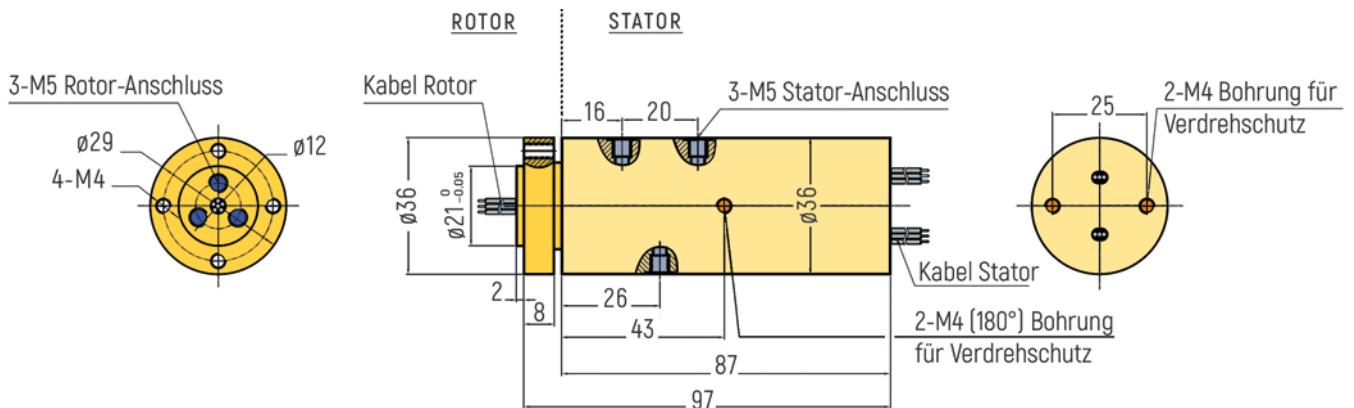

# MINIATUR PNEUMATIK

**ABMESSUNGEN** (in mm)

RX-PM504 - Keine Signalinge

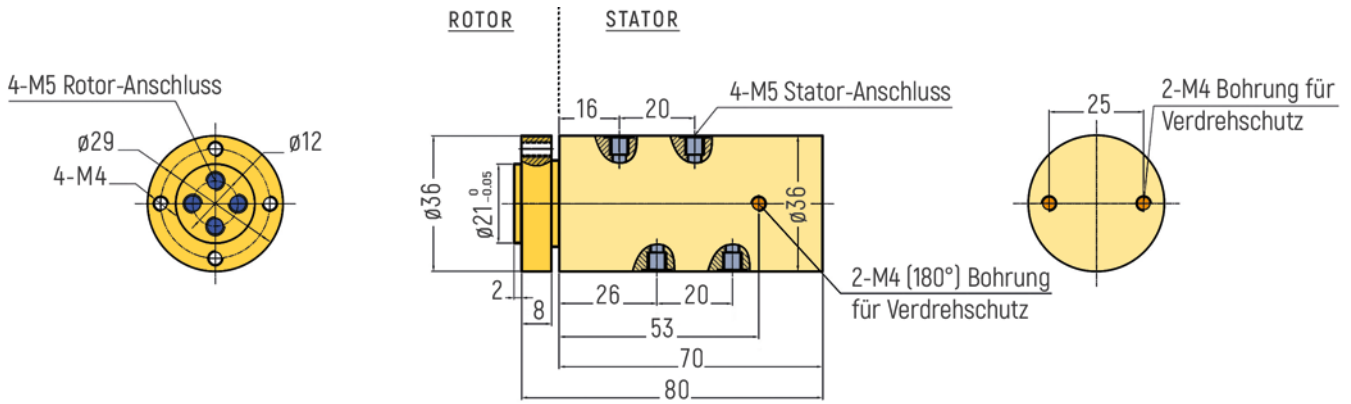

RX-PM504 - 6 Signalinge

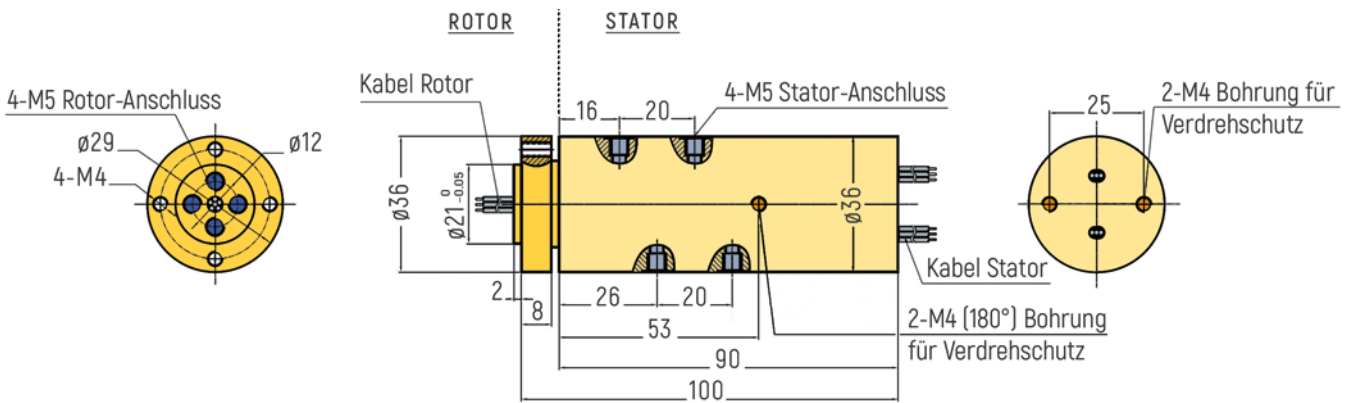

RX-PM504 - 12 Signalinge

