

AUTOMATION

RX-SF056 Serie	p.1	RX-RF056 Serie	p.2
RX-SF086 Serie	p.3	RX-RF086 Serie	p.4
RX-SF119 Serie	p.5	RX-RF119 Serie	p.6

ABMESSUNGEN (in mm)

RX-SF056A - Schleifring mit Stator-Flansch

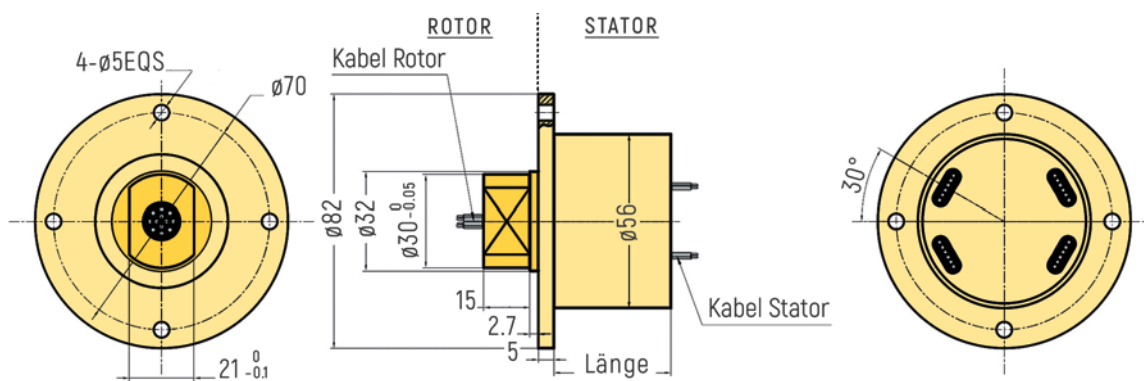

RX-SF056B - Schleifring mit Stator-Flansch

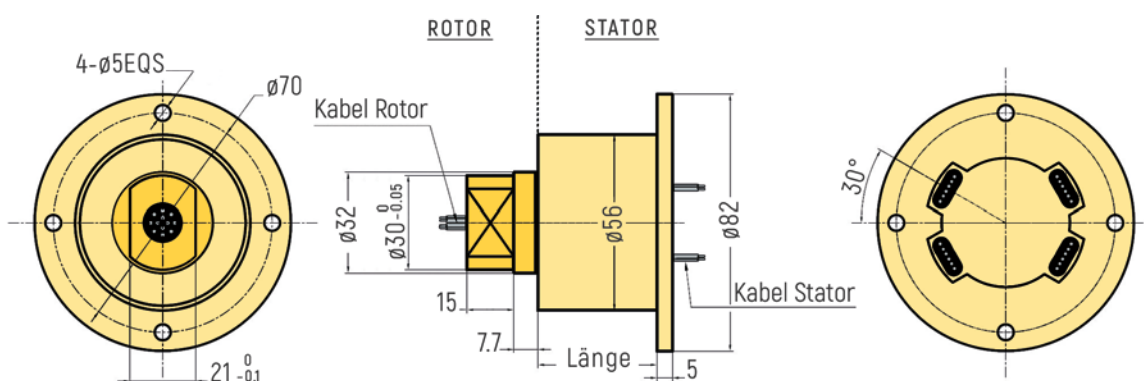

AUTOMATION



ABMESSUNGEN (in mm)

RX-RF056A - Schleifring mit Rotor-Flansch

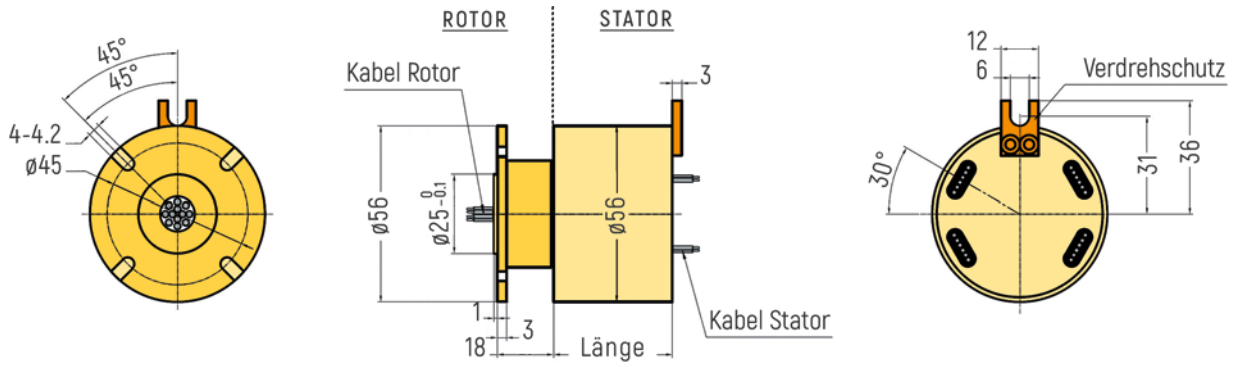

RX-RF056B - Schleifring mit Rotor-Flansch

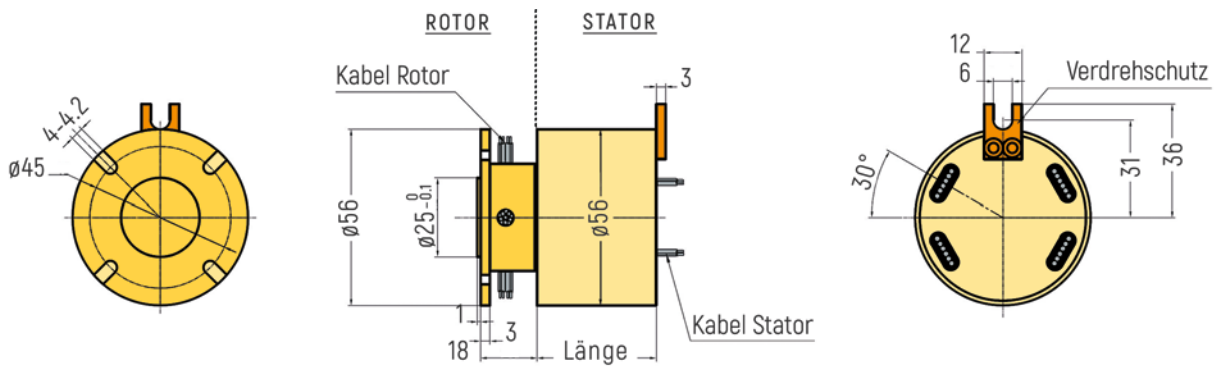

AUTOMATION



ABMESSUNGEN (in mm)

RX-SF086A - Schleifring mit Stator-Flansch

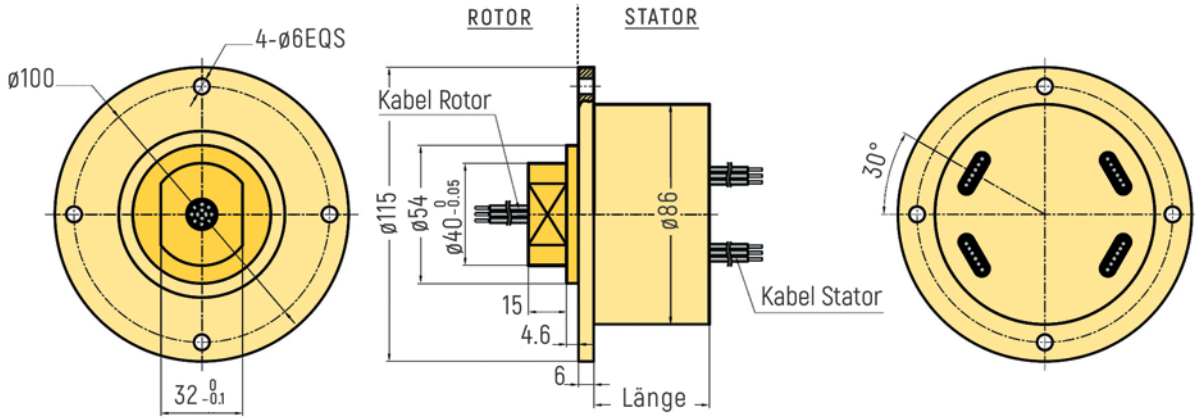

RX-SF086B - Schleifring mit Stator-Flansch

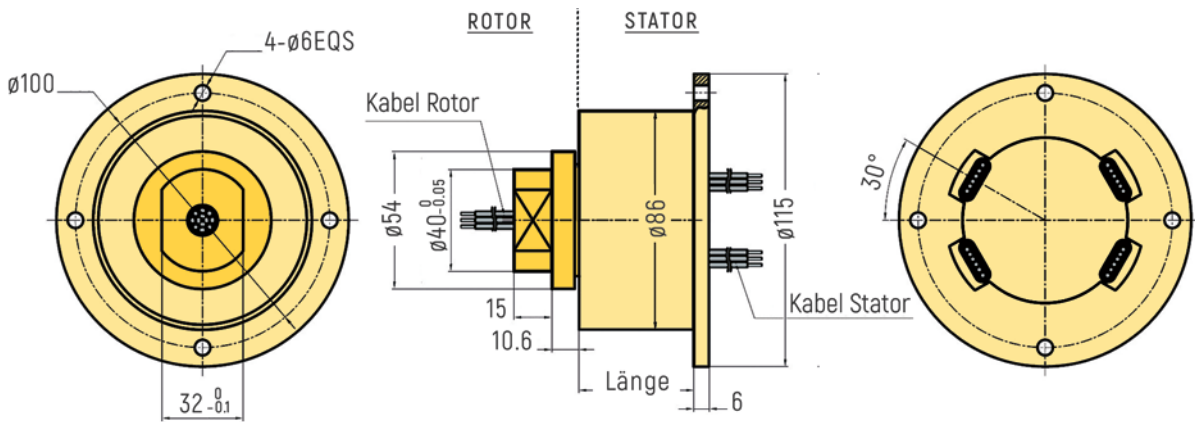

AUTOMATION



ABMESSUNGEN (in mm)

RX-RF086A - Schleifring mit Rotor-Flansch

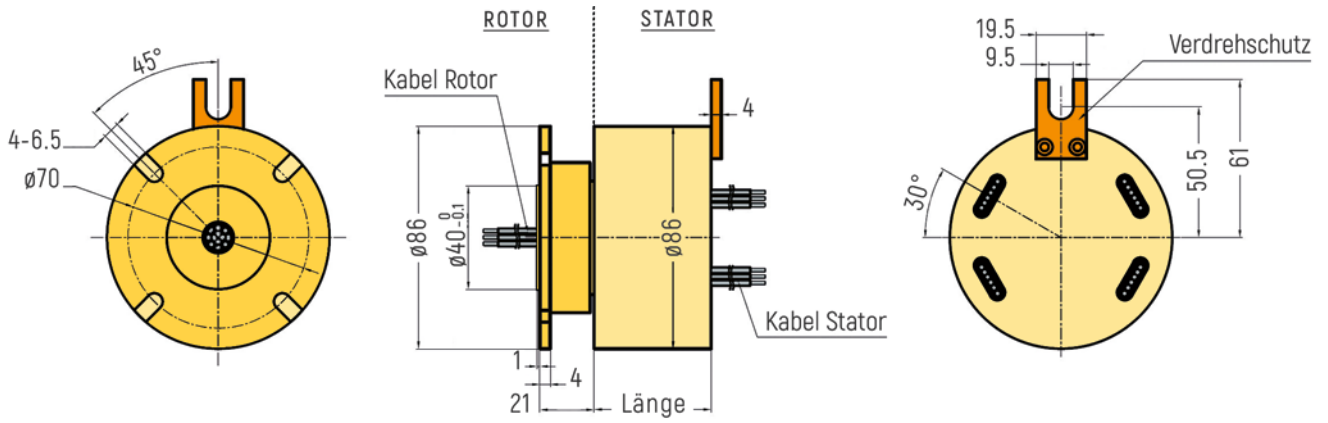

RX-RF086B - Schleifring mit Rotor-Flansch

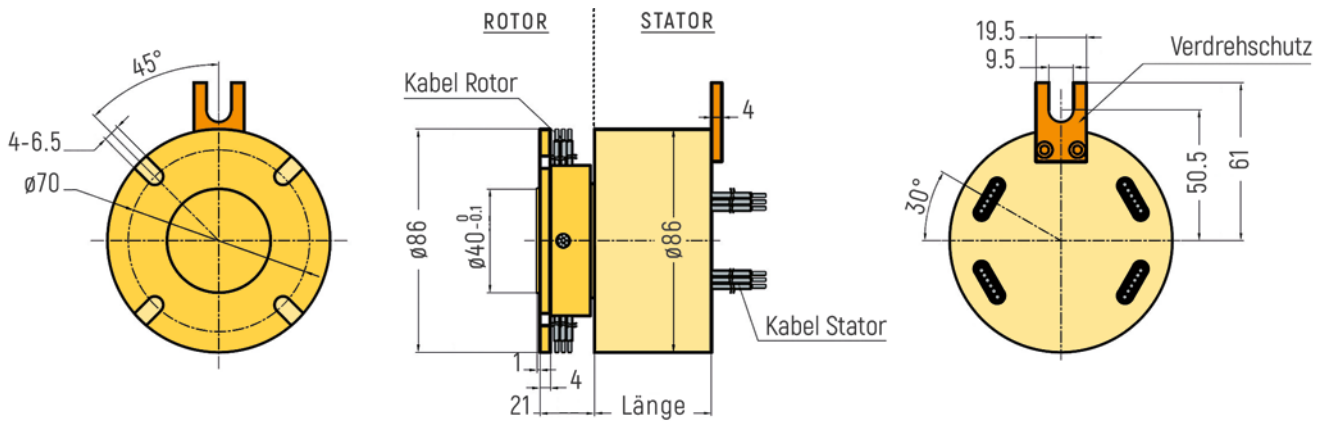

AUTOMATION



ABMESSUNGEN (in mm)

RX-SF119A - Schleifring mit Stator-Flansch

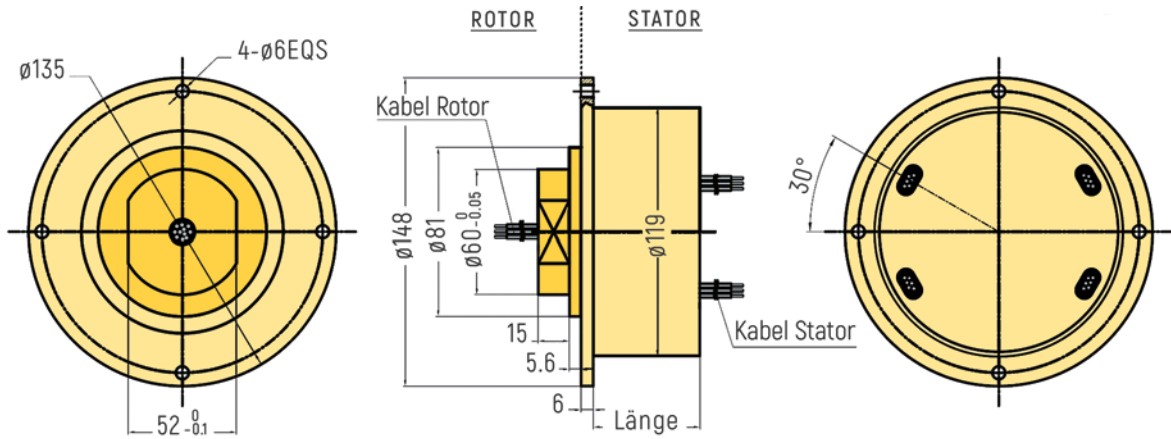

RX-SF119B - Schleifring mit Stator-Flansch

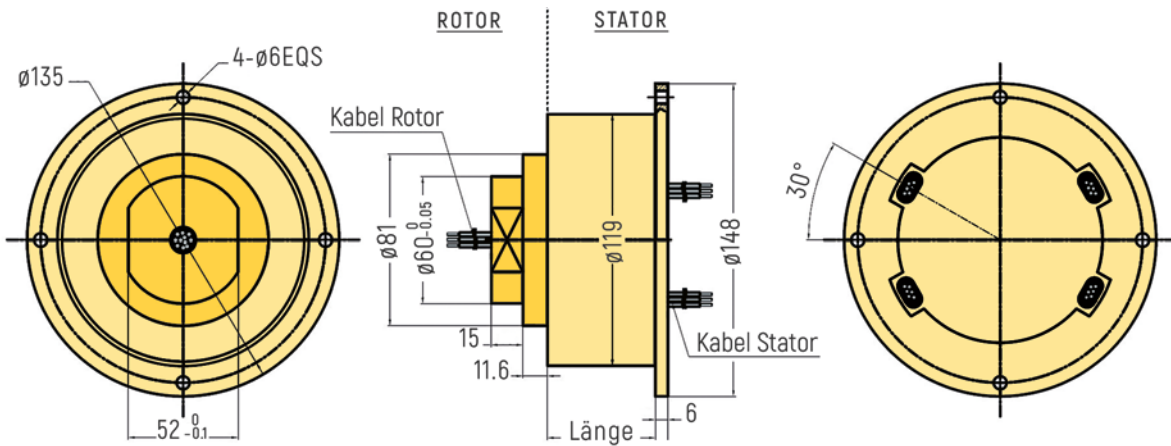

AUTOMATION



ABMESSUNGEN (in mm)

RX-RF119A - Schleifring mit Rotor-Flansch

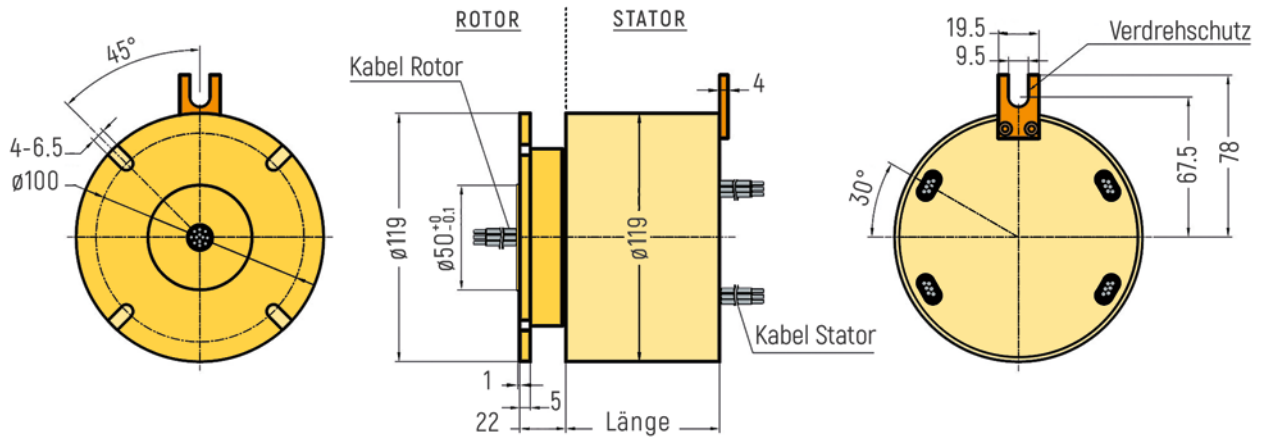

RX-RF119B - Schleifring mit Rotor-Flansch

